



COMMERCE COMMISSION

**STANDARD TERMS DETERMINATION FOR  
TELECOM'S UNBUNDLED BITSTREAM ACCESS  
BACKHAUL SERVICE**

**SCHEDULE 1  
UBA BACKHAUL SERVICE DESCRIPTION  
PUBLIC VERSION**

**Current to final s30R review of 23 March 2011**

**All changes as a result of the draft s30R review are shown as tracked changes. Changes to the original version of this Schedule<sup>1</sup> from earlier clarifications (Decisions 654<sup>2</sup> and 665<sup>3</sup>) do not show as tracked changes.**

---

<sup>1</sup> Available on the Commission's website at <http://www.comcom.govt.nz/assets/Telecommunications/STD/UBA-Backhaul/UBA-Backhaul/Final-UBA-STD-for-Telecoms-UBA-Backhaul-Service-Schedule-1-UBA-Backhaul-Service-Description-27-June-2008.pdf>.

<sup>2</sup> Available on the Commission's website at <http://www.comcom.govt.nz/assets/Telecommunications/STD/UBA-Backhaul/UBA-Backhaul/UBA-Backhaul-STD-Clar-1-Decision-654-Clarification-of-STD-on-Telecoms-UBA-Backhaul-Service-19-September-2008.pdf>.

<sup>3</sup> Available on the Commission's website at <http://www.comcom.govt.nz/assets/Telecommunications/STD/UBA-Backhaul/UBA-Backhaul/Final-UCLL-Backhaul-and-UBA-Backhaul-STD-Clarification-decision-document-5-March-2009.PDF>.

## Table of contents

<b>1</b>	<b>Introduction .....</b>	<b>1</b>
	Background to Market Analysis .....	1
	Definitions .....	1
<b>2</b>	<b>The UBA Backhaul Service.....</b>	<b>3</b>
	Handover Points .....	4
	Primary Links and Secondary Links .....	4
	POI Sites .....	4
	ASNAPoIs .....	5
<b>3</b>	<b>Connection requirements.....</b>	<b>5</b>
<b>4</b>	<b>Transmission capacity .....</b>	<b>6</b>
<b>5</b>	<b>Capacity/geographic availability .....</b>	<b>6</b>
<b>6</b>	<b>Components of the service and associated prices.....</b>	<b>6</b>
<b>7</b>	<b>Service levels .....</b>	<b>6</b>
	<b>Appendix A - UBA Backhaul Service diagram.....</b>	<b>7</b>
	<b>Appendix B - Specification for the UBA Backhaul Service .....</b>	<b>10</b>

## UBA Backhaul Service Description

### 1 Introduction

- 1.1 This UBA Backhaul Service Description is part of the UBA Backhaul Terms, which set out the rights and obligations of Telecom and Access Seekers in relation to Telecom's unbundled bitstream access backhaul.
- 1.2 References to clauses or sections are references to clauses and sections in this UBA Backhaul Service Description unless expressly provided otherwise. Clause 1.3 sets out definitions for terms contained in this UBA Backhaul Service Description that are not defined in the UBA Backhaul General Terms. Otherwise, the definitions set out in the UBA Backhaul General Terms apply.

#### Background to Market Analysis

- 1.2A. The UBA Backhaul Service is only available in the markets for transmission capacity where the Conditions apply.
- 1.2B. In considering the Conditions, the Commission determined that the markets for transmission capacity in which the UBA Backhaul Service are supplied are:
- 1.2B.1. the wholesale markets for transmission capacity between each FDS Handover Point and each ASNAPOI Handover Point of the UBA Backhaul Service; and
- 1.2B.2. the wholesale markets for transmission capacity between each Parent POI Site and each ASNAPOI Handover Point of the UBA Backhaul Service.
- 1.2C. After the coming into force of the Conditions under the Act, the Commission applied the Conditions to all Primary Links and all Secondary Links that were in existence.
- 1.2D. Telecom is not required to supply the UBA Backhaul Service on Links that would otherwise be Primary Links or Secondary Links:
- 1.2D.1. where the Commission has determined that the Conditions do not apply; and
- 1.2D.2. where the Commission has not applied the Conditions.
- 1.2E. For the avoidance of doubt, where a new Primary Link or Secondary Link arises as a result of an increase in geographic availability or coverage of the UBA Backhaul Service, the routes corresponding to new POIs or FDSs will not be available to the Access Seeker unless the Commission has determined that the Conditions apply in the relevant markets for transmission capacity.

#### **Definitions**

- 1.3 Except where expressly provided otherwise:

<b>ASNAPOI</b>	means the Access Seeker's nearest available point of interconnection (as defined in clause 2.8) that is located at a POI Site and is the point at which the Access Seeker is interconnected with Telecom's Network.
<b>ASNAPOI Handover Point</b>	means the Access Seeker side of the data switch in the ASNAPOI.
<b><u>Conditions</u></b>	<a href="#">Telecom faces limited, or is likely to face lessened, competition in the markets for transmission capacity between the FDS and the ASNAPOI as set out in subpart 1 of Part 2 of Schedule 1 of the Act in relation to the UBA Backhaul Service.</a>
<b>DSLAM</b>	means Digital Subscriber Line Access Multiplexer, which is a device that connects many digital subscriber lines to a network by multiplexing the DSL traffic onto one or more network trunk lines.
<b>DSLAM Aggregation</b>	means the process where an Access Seeker's UBA Backhaul Service is collected from one or more DSLAMs and is merged at the FDS.
<b>ETP</b>	means the external termination point for telecommunications services at an End User's premises or, where there is no termination point external to the premises, either the first jack on the premises wiring, or, alternatively, the building distribution frame.
<b>FDS</b>	means the UBA Service first data switch (or equivalent facility) in Telecom's Network where the Access Seeker is being supplied with, or may potentially be supplied with, the UBA Service.
<b>FDS Handover Point</b>	means the Access Seeker side of the data switch in the FDS.
<b>Handover Connection</b>	means the Telecom Owned Equipment that includes:  (a) the trunk port on the FDS or ASNAPOI data switch (as the case may be);  (b) the optical fibre from the port to Telecom's OFDF; and  (c) the OFDF.
<b>Handover Fibre</b>	means the Handover Fibre interconnected with the Handover Connection that provides physical interconnection with the Access Seeker's Network.
<b>Handover Link</b>	means the link comprising a Handover Fibre and a Handover Connection between the ASNAPOI data switch and the Access Seeker's remotely located equipment used for the purpose of handing over traffic for the UBA Backhaul Service.
<b>Link</b>	means a Primary Link and/or a Secondary Link.
<b>OFDF</b>	means Telecom's Optical Fibre Distribution Frame.
<b>Parent POI Site</b>	means, in relation to a FDS, the POI Site to which that FDS is connected for the purposes of routing the UBA Backhaul Service. For the avoidance of doubt, the Parent POI Site may sometimes be the same as the ASNAPOI.
<b>POI Site</b>	means a point in Telecom's Network at which the Access Seeker may interconnect for the purposes of the UBA Backhaul Service.

<b>Primary Link</b>	means that part of the UBA Backhaul Service between the FDS Handover Point and the Parent POI Site.
<b>Primary Link Aggregation</b>	means, the process where an Access Seeker's UBA Backhaul Service is collected from one or more FDSs and is merged at the Parent POI.
<b>Secondary Link</b>	means that part of the UBA Backhaul Service between the Parent POI Site and the ASNAPOI Handover Point.
<b>UBA Service</b>	means that part of the UBA Service that is described as the "enhanced unbundled bitstream access service" set out in section 4 of the UBA Service Description and, for the avoidance of doubt, excludes that part of the UBA Service described as the "basic unbundled bitstream access" set out in section 3 of the UBA Service Description.
<b>UBA Service Description</b>	means the UBA Service Description in Schedule 1 of the standard terms determination dated 12 December 2007 in relation to the designated service of "Telecom's unbundled bitstream access" in subpart 1, Part 2 of Schedule 1 of the Act (Commission Decision 611).

## 2 The UBA Backhaul Service

- 2.1 Telecom's UBA Backhaul Service is a service (and its associated functions, including the associated functions of Telecom's operational support systems) that provides transmission capacity in Telecom's network (whether the transmission capacity is copper, fibre, or anything else) between the trunk side of [the FDS Handover Point](#) that is connected to the End User's building (or, where relevant, the building distribution frames) and the ASNAPOI Handover Point.
- 2.2 The UBA Backhaul Service is for the purpose of the UBA Service. Transmission capacity is provided as an ethernet connection. A diagram of the UBA Backhaul Service is attached as Appendix A and a specification of the UBA Backhaul Service is set out in Appendix B.

2.2A. [Subject to clause 1.2E, the UBA Backhaul Service is available on all Primary Links and Secondary Links of the UBA Backhaul Service because the Conditions apply.](#)

### Handover Points

- 2.3 The handover points for the UBA Backhaul Service are the FDS Handover Point and the ASNAPOI Handover Point.

### Primary Links and Secondary Links

- 2.4 Where an Access Seeker requests the UBA Backhaul Service from a particular FDS, Telecom must provide the UBA Backhaul Service between the FDS Handover Point and the ASNAPOI Handover Point. The UBA Backhaul Service from that FDS [Handover Point](#) may comprise a Primary Link only, a Primary Link and a Secondary Link, or a Secondary Link only, depending on the location of the FDS and the ASNAPOI as follows:

- 2.4.1 where the FDS is not a POI Site and the Parent POI Site in relation to that Local Exchange is not an ASNAPOI, the UBA Backhaul Service will consist of a Primary Link and a Secondary Link;
- 2.4.2 where the FDS is not a POI Site and the Parent POI Site in relation to that FDS is an ASNAPOI, the UBA Backhaul Service will consist solely of a Primary Link;
- 2.4.3 where the FDS is a Parent POI Site and that POI Site is not an ASNAPOI, the UBA Backhaul Service will consist solely of a Secondary Link; and
- 2.4.4 where the FDS is a POI Site and that POI Site is an ASNAPOI, the UBA Backhaul Service is not required and available in relation to that FDS.

Where necessary, the Access Seeker may purchase more than one Secondary Link between the same POI Site and the same ASNAPOI to obtain access to sufficient transmission capacity for the purposes of the Primary Links.

### POI Sites

- 2.5 The UBA Backhaul Service includes a number of POI Sites in Telecom's Network. The UBA Backhaul Service for a FDS is routed through the Parent POI Site for that FDS.
- 2.6 Telecom may from time to time as its Network evolves, add, delete or move POI Sites and must provide the Access Seeker and the Commission with notice of any changes to the POI Sites in accordance with the UBA Backhaul Operations Manual. Lists of POI Sites, and Parent POI Sites and their associated FDSs, are set out in Schedule 5 to the UBA Backhaul General Terms. These lists must be made available to Access Seekers via a secure Telecom web portal and must be regularly updated by Telecom where required.
- 2.7 If requested by the Access Seeker, Telecom may designate any of its UBA Service FDSs as a new POI Site. Where Telecom designates a new POI Site, Telecom must provide the Access Seeker with notice of the change in accordance with the UBA Backhaul Operations Manual. The Access Seeker may then establish an ASNAPOI at that new POI Site in accordance with clause 2.8.

### ASNAPoIs

2.8 A POI Site is the ASNAPoI in respect of a FDS for an Access Seeker if the requirements of 2.8.1 and 2.8.2 are satisfied:

2.8.1 the POI Site is an available point of interconnection (as set out in clause 2.9); and

2.8.2 the POI Site is the nearest, as measured by Telecom's network path, of the available points of interconnection (as set out in clause 2.9) to the FDS.

For the purpose of clause 2.8.2, a list of the distances in Telecom's network path between POI Sites is available to Access Seekers via a secure Telecom web portal and must be regularly updated by Telecom where required. For the avoidance of doubt, the Parent POI Site for a FDS is the nearest POI Site to that FDS as measured by Telecom's network path. Therefore, subject to clause 2.8.2, if the Parent POI Site for a FDS is an available point of interconnection, the Parent POI Site is the ASNAPoI in respect of that FDS.

2.9 A POI Site is an available point of interconnection for an Access Seeker if one of the following holds:

2.9.1 the Access Seeker is physically interconnected using the Access Seeker's own equipment with Telecom's Network at that POI Site; or

2.9.2 the Access Seeker has an agreement with a backhaul provider (either with Telecom or a third party provider) for the supply of a service that is equivalent to the UBA Backhaul Service from that POI Site to the Access Seeker's Network.

2.10 The Access Seeker must establish an ASNAPoI at a minimum of one POI Site, but may establish an ASNAPoI at more than one POI Site.

2.11 The Access Seeker may from time to time as its Network evolves, add, delete or move an ASNAPoI. The Access Seeker must provide Telecom with a forecast of any change to its ASNAPoI Handover Point and FDS Handover Point for the UBA Backhaul Service in accordance with the UBA Backhaul Operations Manual.

## 3 Connection requirements

3.1 The Access Seeker, or a third party on behalf of the Access Seeker, must be able to access the UBA Backhaul Service from Telecom at the ASNAPoI by way of a Handover Link.

3.2 Telecom must supply and install the Handover Connection. Either the Access Seeker or Telecom must supply the Handover Fibre, and Telecom must install the Handover Fibre.

3.3 For the avoidance of doubt, an Access Seeker may use an unused fibre pair in Handover Fibre cable already installed for another Telecom-supplied service for the purpose of using the UBA Backhaul Service.

3.4 Prior to provision of the UBA Backhaul Service, the Access Seeker must advise Telecom of the location of its ASNAPoIs and the interconnection arrangements for each ASNAPoI.

3.5 Telecom must provide transmission capacity between the FDS at which the Access Seeker requires the UBA Backhaul Service and the ASNAPoI using where required DSLAM Aggregation at the FDS and Primary Link Aggregation at the relevant Parent POI Site. For the avoidance of doubt, Aggregation of Secondary Links does not occur at the ASNAPoI.

3.6 The Access Seeker may combine the UBA Service with the UBA Backhaul Service on the same Handover Connection.

3.7 The UBA Backhaul Service is not available for direct resale to End Users. However, the UBA Backhaul Service

may be resold by the Access Seeker to other Access Seekers for transmission capacity for the purposes of the UBA Service. For the avoidance of doubt, this clause is not intended to prevent the Access Seeker from reselling the end-to-end UBA Service to other Access Seekers.

#### **4 Transmission capacity**

- 4.1 The UBA Backhaul Service provides transmission capacity at 50Mbit/s, 100Mbit/s, 200Mbit/s or 1Gbit/s. It is the responsibility of the Access Seeker to purchase sufficient capacity and to manage and dimension its UBA Backhaul Service traffic to achieve the relevant UBA Service specifications.

#### **5 Capacity/geographic availability**

- 5.1 Telecom must provide the UBA Backhaul Service in accordance with standard access principles (including access principle 3) in subpart 1 of Part 1 of Schedule 1 of the Act. Without limiting the foregoing, when there is limited capacity between the FDS Handover Point and the ASNAPOI Handover Point Telecom must not discriminate between a request for the UBA Backhaul Service from an Access Seeker and any request for transmission capacity from a division of Telecom.

#### **6 Components of the service and associated prices**

- 6.1 The service components of the UBA Backhaul Service and associated prices are set out in the UBA Backhaul Price List.

#### **7 Service levels**

- 7.1 The applicable service levels are set out in the UBA Backhaul Service Level Terms.

## Appendix A - UBA Backhaul Service diagram

The UBA Backhaul Service is illustrated in the diagrams below.

Diagram A: Primary Link and Secondary Link required

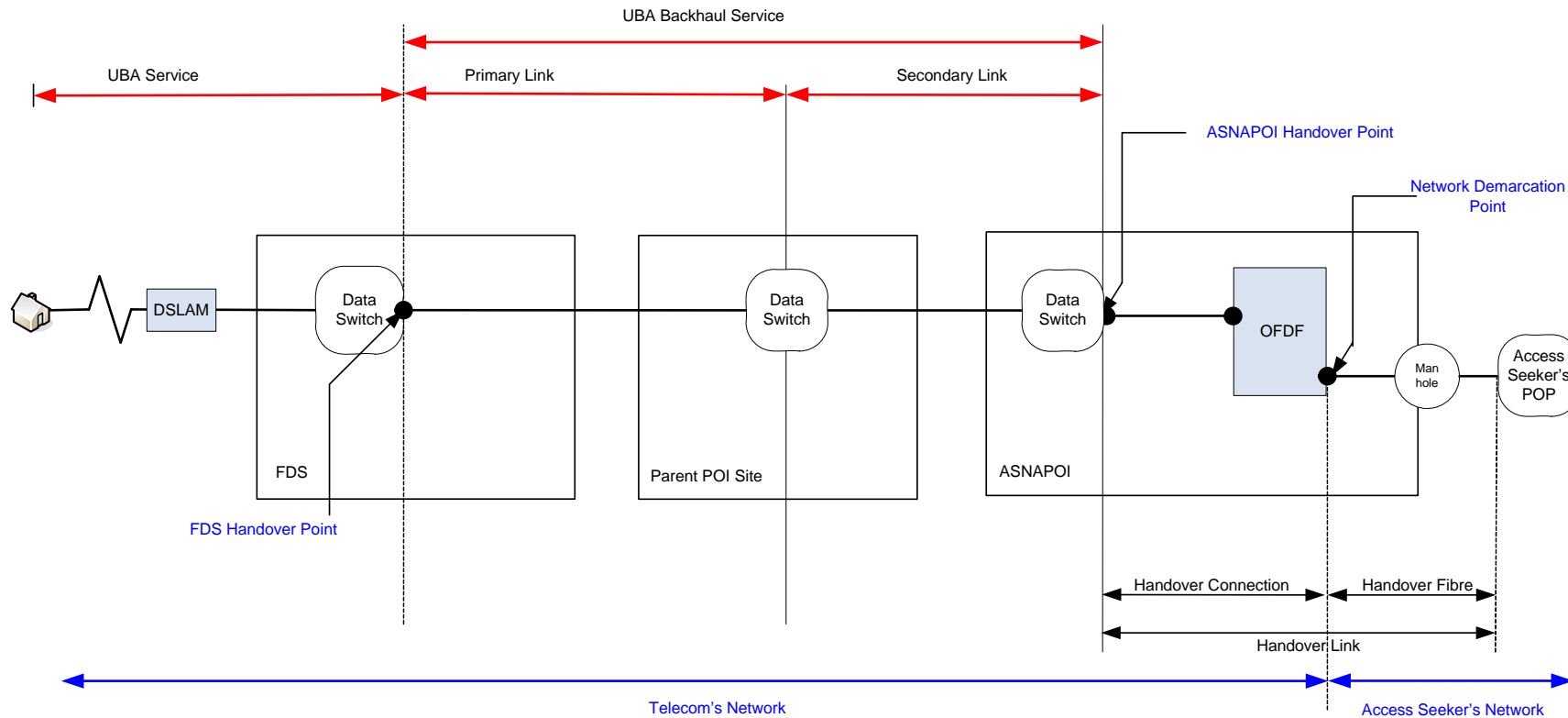

Key for diagrams A, B and C

- M = manhole.
- In relation to that part of the above diagram that is governed by the UBA Service, a more detailed diagram relating to the UBA Service is found in the UBA standard terms

determination.<sup>4</sup>

Diagram B: Primary Link only required (i.e. Parent POI Site is ASNAPOI)

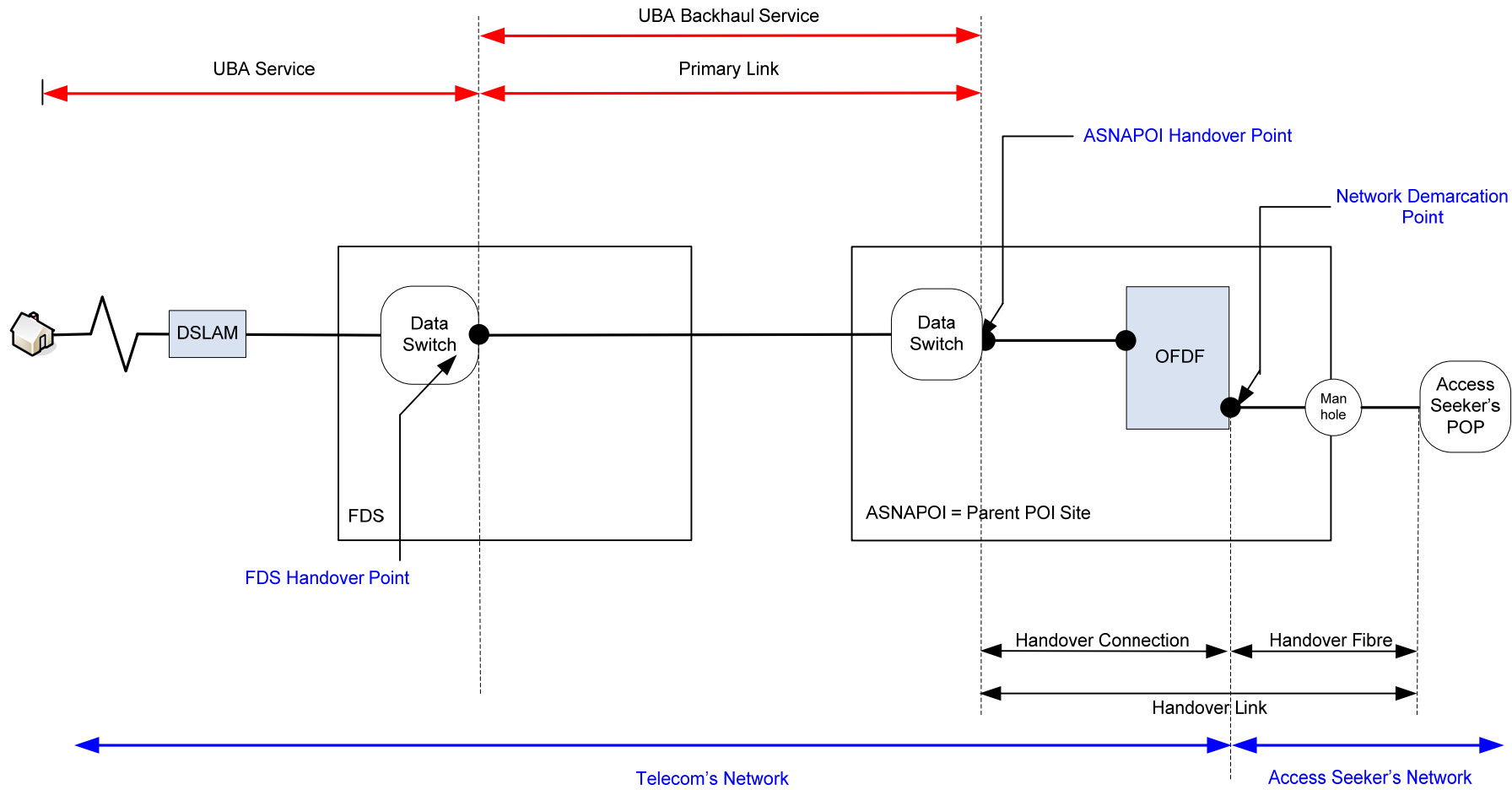

<sup>4</sup> Commerce Commission, *Decision No. 611: Standard Terms Determination for the designated service Telecom's unbundled bitstream access*, 12 December 2007, p 22.

Diagram C: Secondary Link only required (i.e. FDS is Parent POI Site)

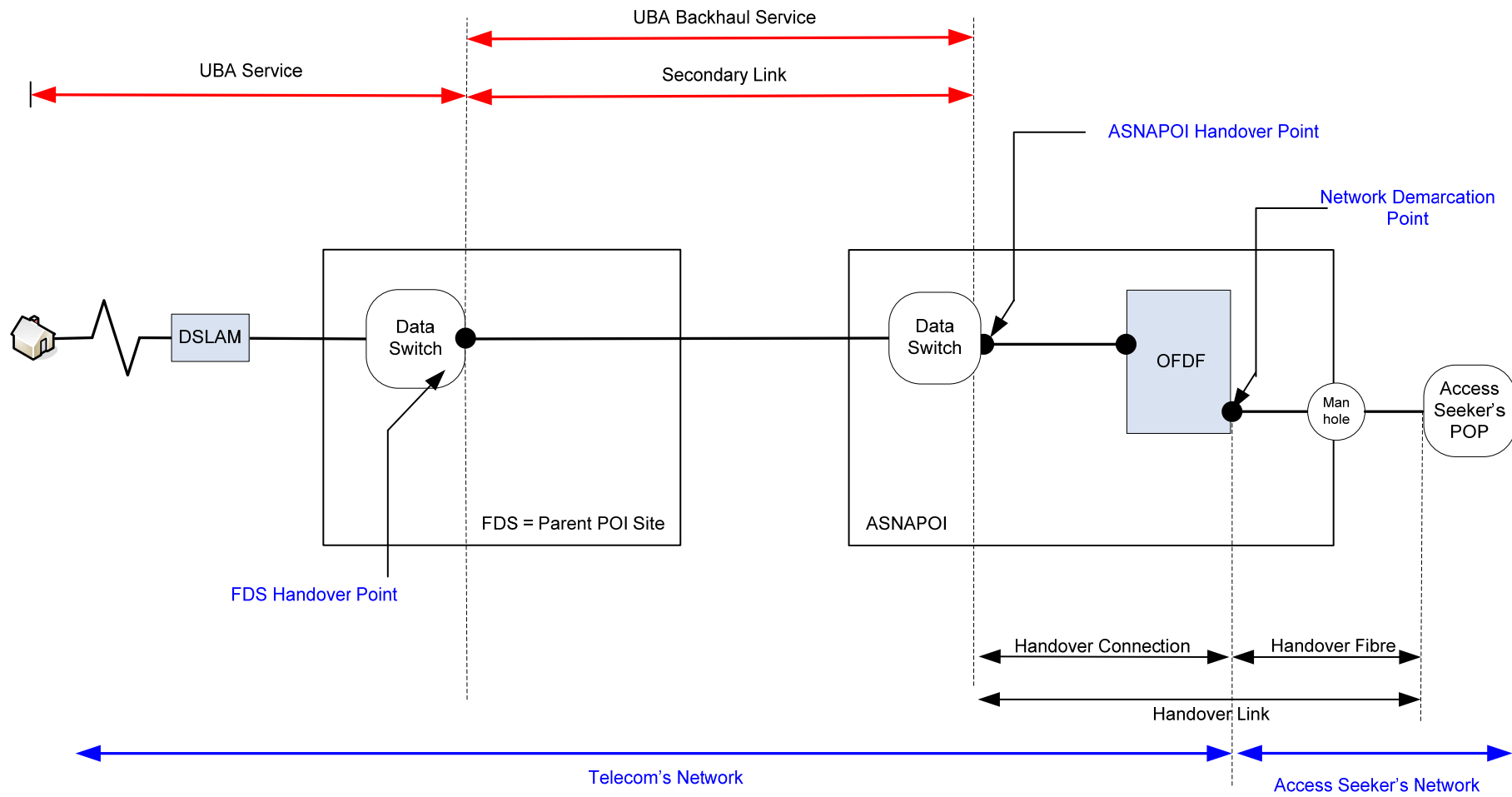

## Appendix B - Specification for the UBA Backhaul Service

The characteristics of the UBA Backhaul Service available under this service description are:

Characteristics	Explanation of the Characteristics
1. Handover Interface	Optical Gigabit ethernet (as per the ethernet handover user guide), ethernet IEEE802.1ad.
2. Maximum Supported Frame Size	1600 bytes including all frame header bytes.
3. Upstream Traffic Management – FDS	<p>Where the UBA Backhaul Service traffic passes through DSLAM Aggregation at the FDS, it must be subjected to Traffic Management to the relevant Transmission Capacity.</p> <p>Where the traffic, at any time, offered to the UBA Backhaul Service exceeds the Transmission Capacity, traffic must be admitted to the UBA Backhaul Service based on (IEEE 802.1p) priority values as set out in characteristic 8 set out below. Traffic marked with lower priority values must be discarded first.</p> <p>All UBA Backhaul Service traffic at the FDS may be subjected to Traffic Policing to the relevant Transmission Capacity.</p> <p>Telecom may encapsulate all packets in the UBA Backhaul Service for the purposes of transmission over Primary Links.</p>
4. Traffic treatment within the UBA Backhaul Service	Traffic within the UBA Backhaul Service may be handled as a single class, however must remain in accordance with the Latency and Jitter specifications set out below.
5. Upstream Traffic Management – Parent POI Site	<p>Traffic will be managed to 1 Gbit/s (the handover rate) in accordance with Traffic Management.</p> <p>Traffic Management may at Telecom’s discretion occur at a Parent POI Site for traffic from an associated FDS, such traffic will be treated as high priority.</p> <p>Traffic from a FDS located in the Parent POI will be managed based on (IEEE 802.1p) priority values as set out in characteristic 8 set out below. Traffic marked with lower priority values must be discarded first.</p> <p>Primary Link Aggregation occurs at the Parent POI Site for the UBA Backhaul Service traffic.</p> <p>All UBA Backhaul Service traffic at the Parent POI may be subjected to Traffic Policing to the relevant Transmission Capacity.</p>
6. Downstream Traffic Policing – Handover Link	There will be no downstream Traffic Management at the Handover Link. UBA Backhaul Service traffic will be accepted up to the line rate of the Handover Link.
7. Downstream Traffic Policing – UBA Backhaul Service	UBA Backhaul Service traffic is subject to Traffic Policing to the Transmission Capacity. Telecom must not act on priority values.
8. Priority	Priority must be based on the (IEEE802.1p) priority values, supported by the UBA Service. <sup>5</sup> Treatment of traffic with non-supported priority values is not defined in the UBA Backhaul Service Description.

<sup>5</sup> Ibid.

9. Transmission capacity	The gross service capacity including all valid frames and protocol overheads.
10. VLAN Tagging	Access Seekers are responsible for ensuring the end to end uniqueness of their VLAN.
11. Latency <sup>6</sup>	For a Link that comprises a Primary Link only: < 5msec  For a Link that comprises a Primary Link and a Secondary Link, or a Secondary Link only: < 25msec
12. Jitter <sup>7</sup>	For a Link that comprises a Primary Link only: < 3msec  For a Link that comprises a Primary Link and a Secondary Link, or a Secondary Link only: < 7msec
13. Availability	99.5% measured over a 12 month period.

For the avoidance of doubt, there is no Traffic Management from the Parent POI Site to the ASNAPOI (assuming the Parent POI is not the ASNAPOI). Therefore the Access Seeker must purchase sufficient capacity to ensure that the UBA Backhaul Service traffic obtains the required priority. However, between the FDS and the Parent POI Site, Telecom must supply Traffic Management to the Access Seeker.

Definitions for the purposes of Appendix B:

- IEEE 802.1ad** means an amendment to the IEEE standard 802.1Q-1998 and is a standardised version of a feature known as QinQ or Stacked VLANs which was approved in 2005.
- Transmission Capacity** means the capacity of the Primary Link or Secondary Link (.e 50Mbit/s, 100Mbit/s, 200Mbit/s and 1Gbit/s).
- Traffic Policing** means the process of monitoring the UBA Backhaul Service traffic to ensure that the traffic is constrained and, if required, dropping some traffic.
- Traffic Management** means Telecom’s process whereby higher priority UBA Backhaul Service traffic is prioritised over lower priority UBA Backhaul Service traffic according to the priority specifications set out in characteristic 8 above..
- VLAN** means the Virtual Local Area Network which is a virtual connection on a point-to-point ethernet link and is the basic building block of the UBA Backhaul Service.
- VLAN Tag** means four bytes of data in the ethernet header that identify the packet as an 802.1ad frame.

---

<sup>6</sup> Latency or the mean one way packet delay shall be evaluated over an interval of 15 minutes for all classes.

<sup>7</sup> Jitter or the packet delay variation means the packet transfer delay (PTD) upper minus PTD min where PTD upper is the 99.9% quartile of PTD in the evaluation interval, and PTD min is the minimum PTD in the evaluation interval. The evaluation interval must be 15 minutes.