

Commerce Commission Workshop on UBS Technical Issues - Backhaul

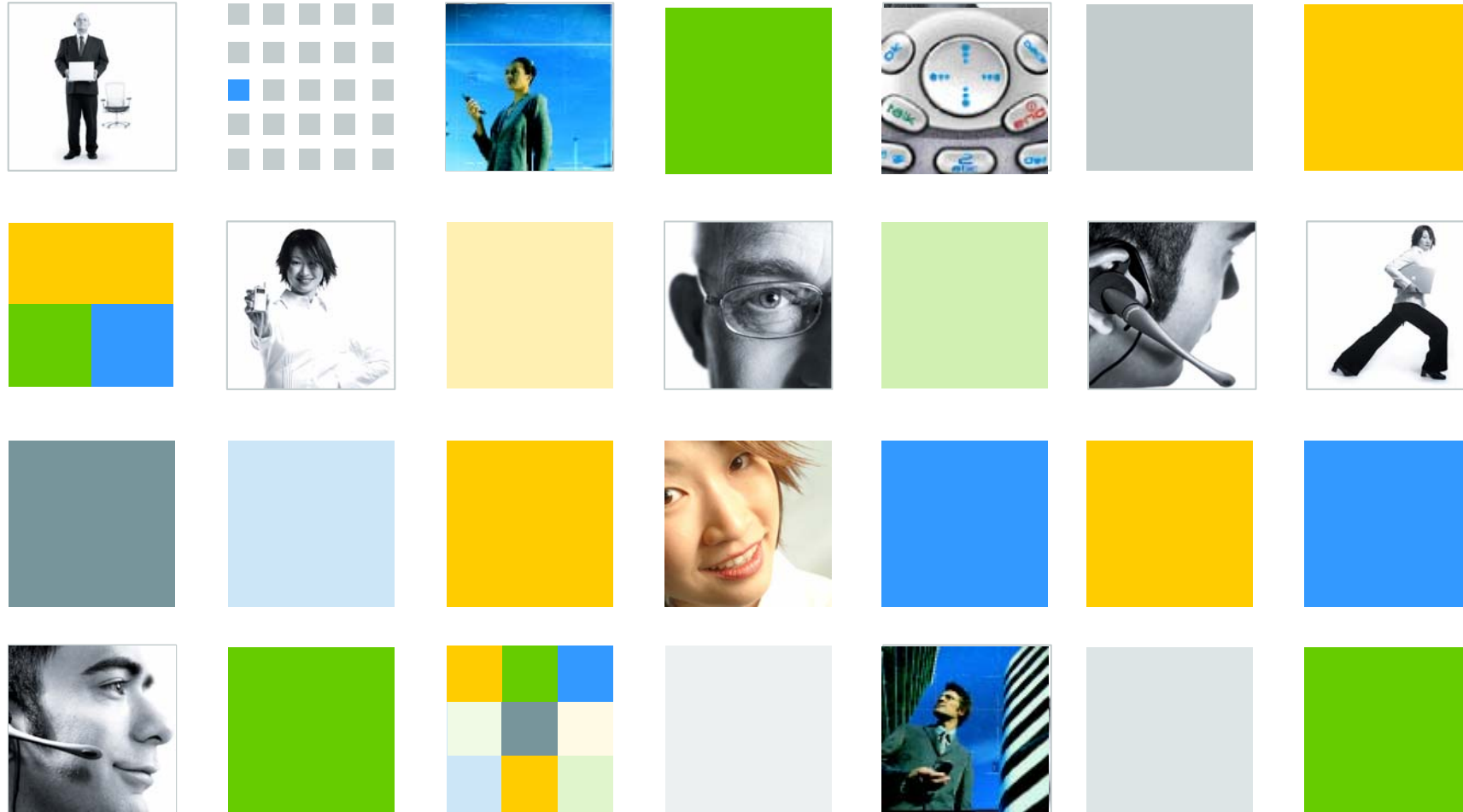

Telecom New Zealand
11 February 2005



Provision of Backhaul Service



Is it necessary to take backhaul without breaking the service down into URSAs where the Access Seeker does and does not have their own infrastructure in place to supply their own backhaul?

Backhaul Options available to TelstraClear

- Option 1 - Self Provision of Backhaul

- TCL manage size/placement of links therefore no usage limitation
- **Option 1a** - Use own Network assets to create NNI links to URSAs
- **Option 1b** - URSAs beyond the reach of existing assets can be reached with purchase of Telecom Wholesale Data Services

OR

- Option 2 - Telecom Flexible Backhaul Service

- TCL decide number of NNI(s), pay for backhaul on a customer by distance basis
 - Telecom manages bandwidth/geographic distribution risk therefore a throughput charge is levied if the average allowance (10GB) per connection is exceeded.

10 Gigabyte allowance

- Telecom's most popular JetStream plan had a usage allowance of 1GB month.
- In order to compete with this plan at retail, ISPs were offered a backhaul price that included 10GB of traffic.
- By making various plan offerings at retail, an ISP can compete with Telecom without paying additional backhaul traffic fees.

	Connections		Plan Allowance	Traffic Total
	1000	x	2 GB	2000 GB
	500	x	10 GB	5000 GB
	100	x	50 GB	5000 GB
	40	x	100 GB	4000 GB
Total	1640			16000 GB

Total connections (1640) x allowance (10GB) results in a total traffic allowance of 16400 GB which exceeds the traffic consumed by this mix of customer plans.



Backhaul



Telecom developed a $n \times 2M$ UBR backhaul service (Option 1) specifically for the UBS service.

Telecom offers a range of Wholesale Data services that can be used by Access Seekers to develop their own backhaul links / augment their existing network (Option 1b).

As a result of industry consultation and in response to industry feedback, Telecom developed a Commercial Flexible Backhaul service (Option 2) to suit Access Seekers who did not want to manage the vagaries of backhaul dimensioning and geographic distribution of their customer base.

UBS Backhaul

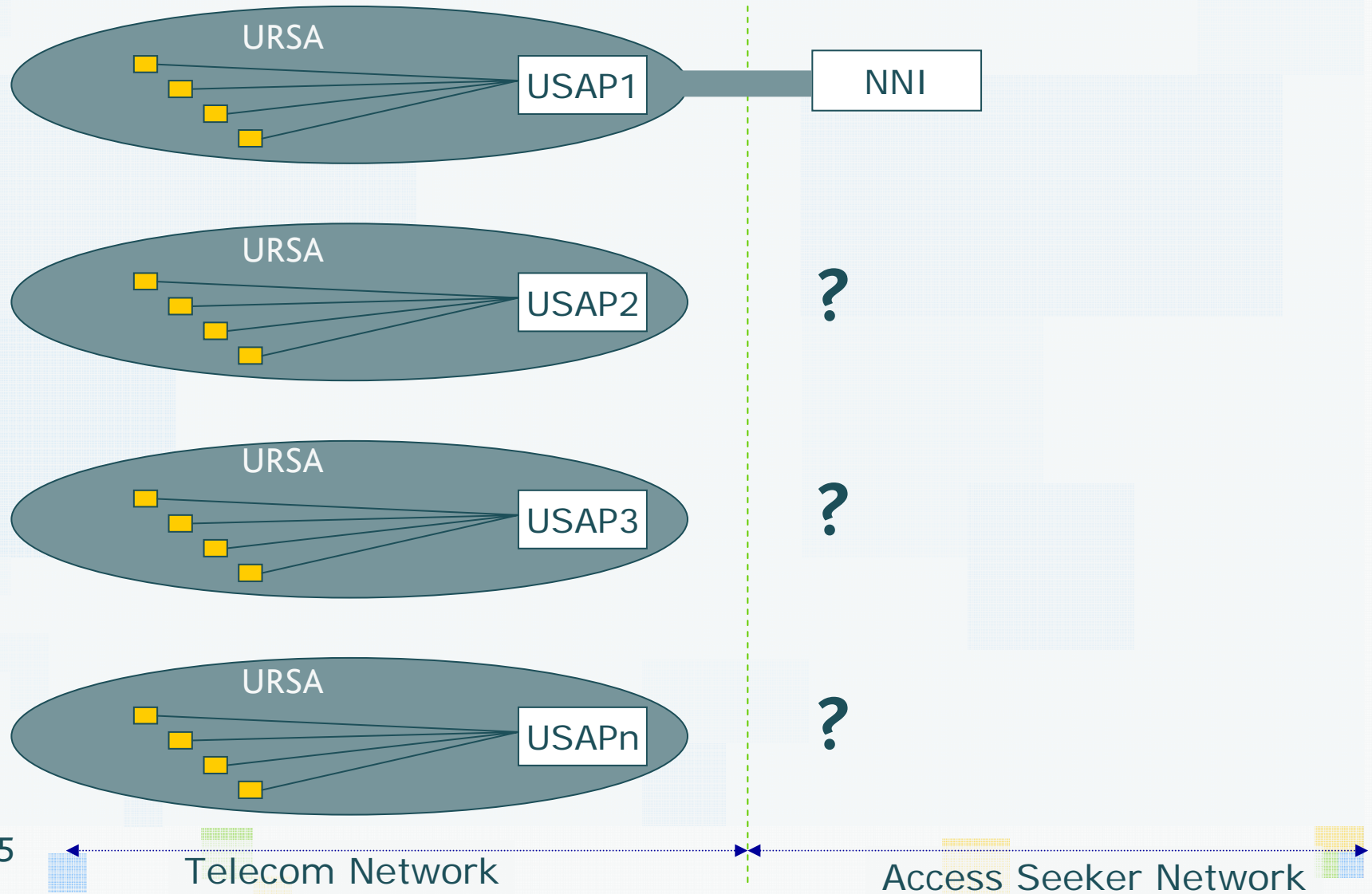

UBS Backhaul – Self Provide – Option 1a

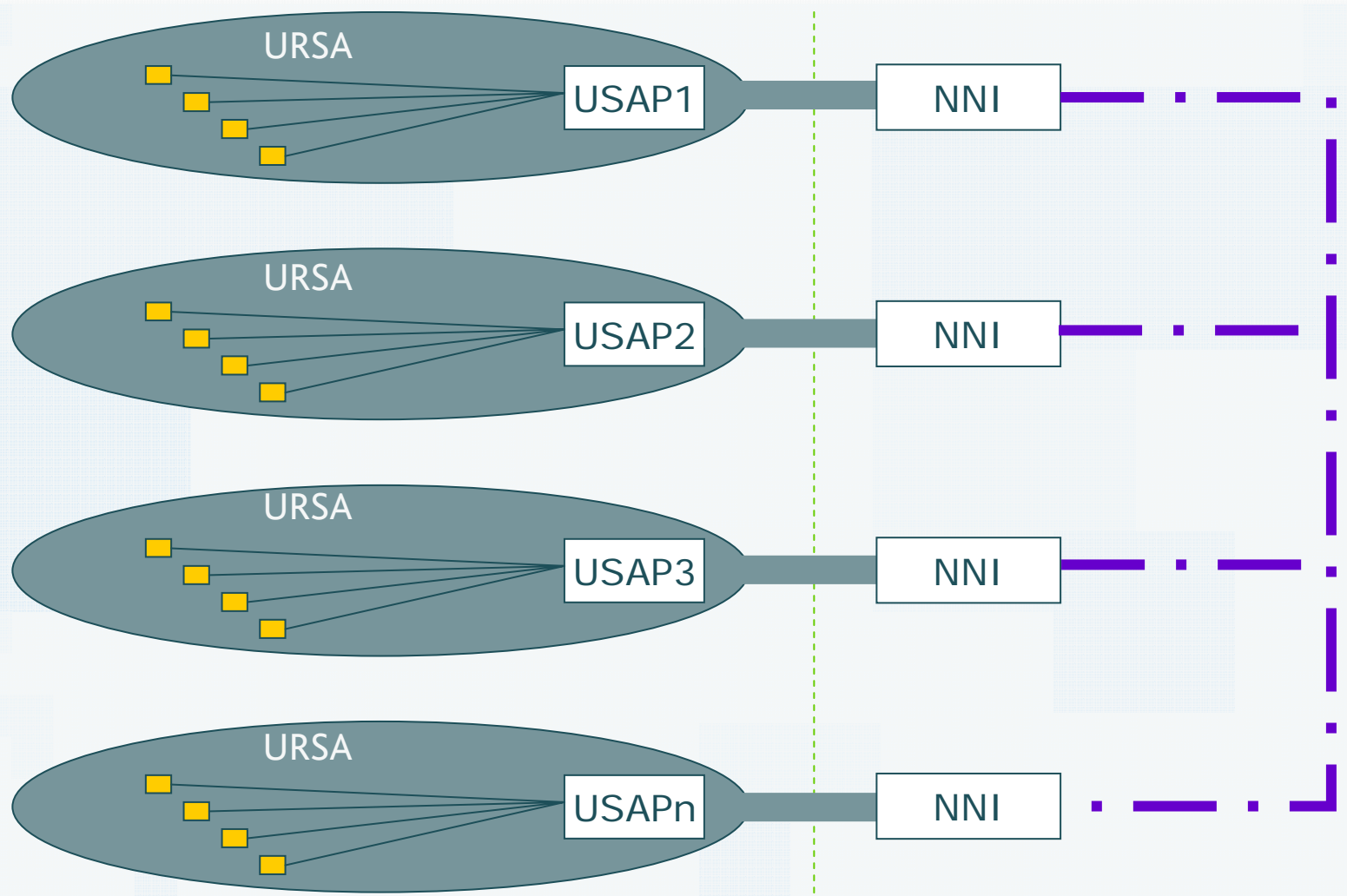

6

Telecom Network

Access Seeker Network

UBS Backhaul – Self Provide – Option 1b

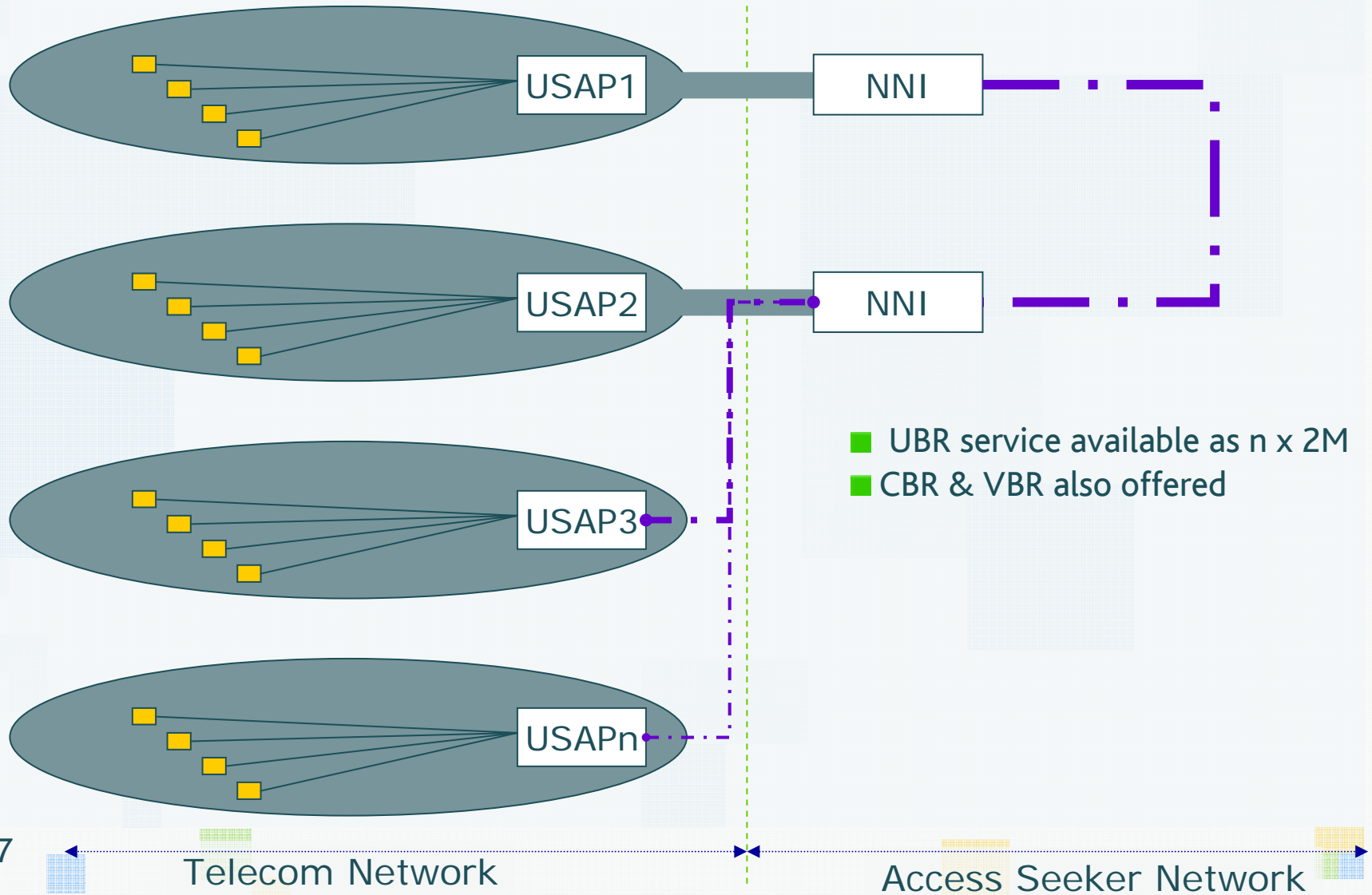

UBS Flexible Backhaul – Option 2

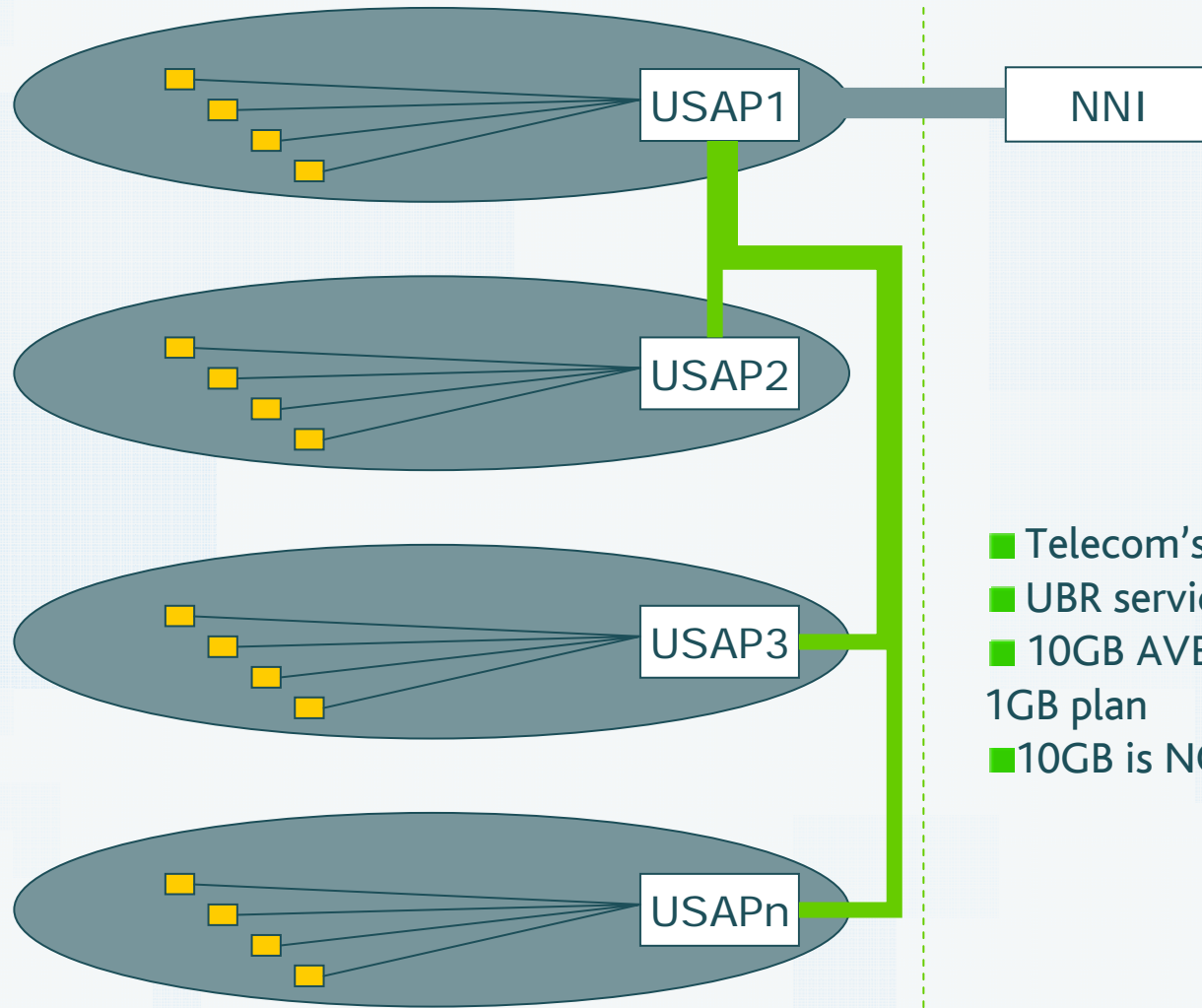

- Telecom's response to industry feedback
- UBR service
- 10GB AVERAGE based on Telecom retail 1GB plan
- 10GB is NOT a hard limit

UBS Flexible Backhaul – Option 2

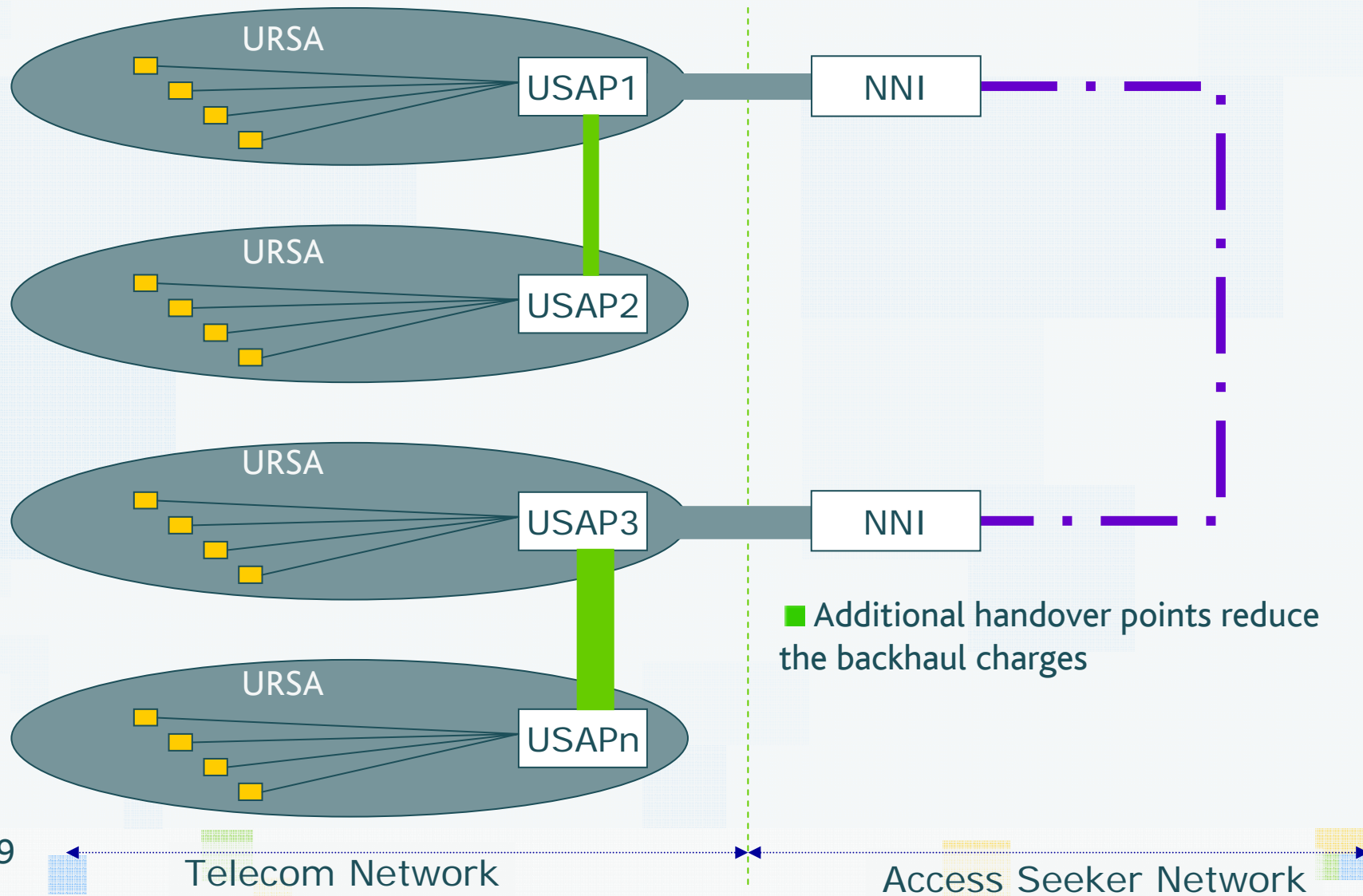

UBS Backhaul – UPC/UBS/Commercial mix

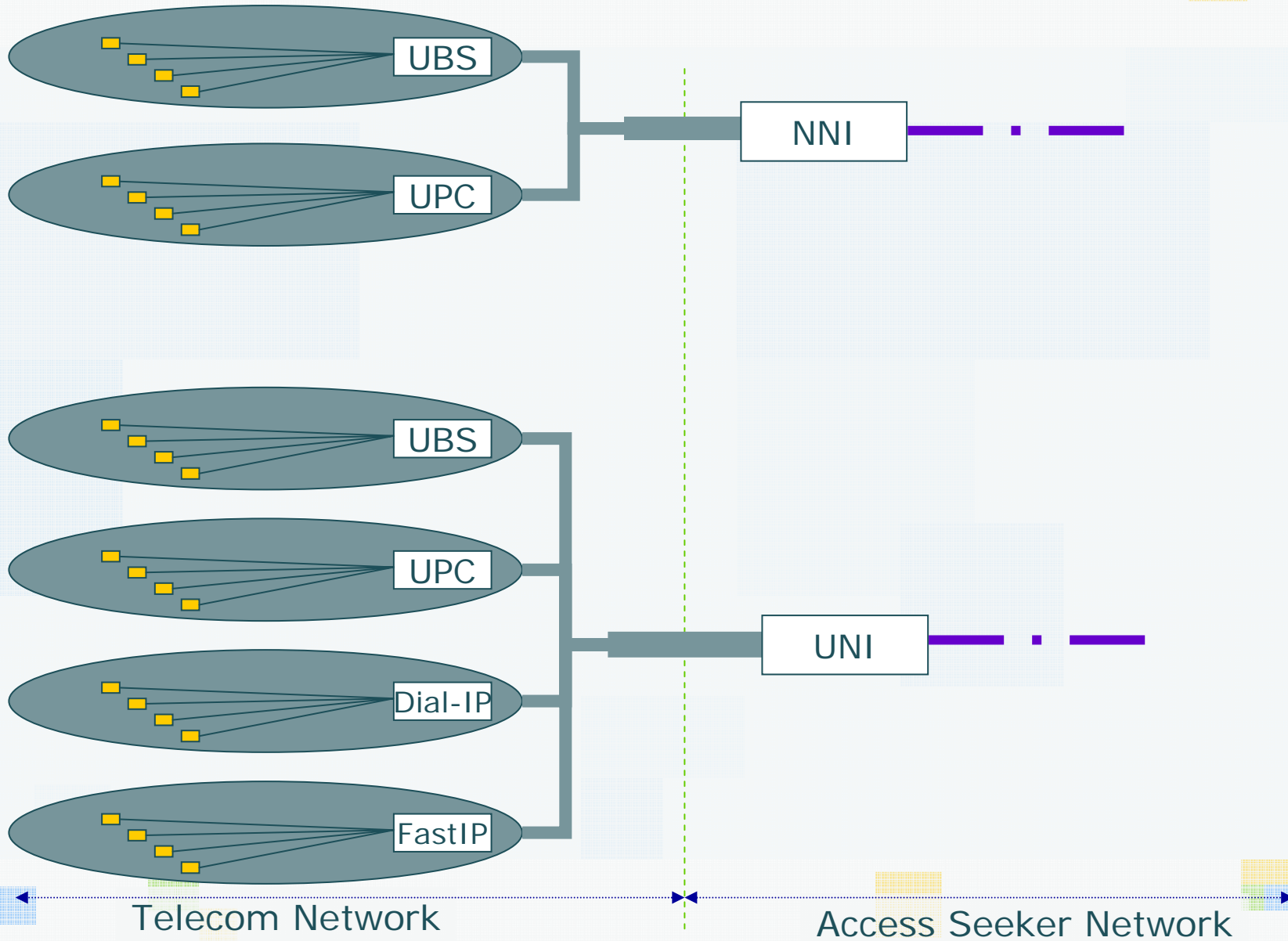



Provision of Backhaul Service

Answer:

The URSA structure is a necessary consequence of the regulated service being defined to the first ATM switch – this is the point from which backhaul needs to be provided by the access seeker, or purchased from Telecom.

There are a range of backhaul options available to all service providers for connection to Telecom ATM switches (USAPs).

Under the self-provide option (Option 1) the access seeker builds to all USAPs, build to a sub-set of URSA, or alternatively purchases dedicated fixed capacity links from Telecom.

The flexible backhaul service (Option 2) is a commercial construct developed in response to consultation that particularly meets the needs of smaller service providers. It cannot be mixed with Option 1 on an ad hoc basis.

Backhaul Options available to TelstraClear

- Self Provision of Backhaul – Option 1

- TCL manage size/placement of links therefore no usage limitation
- Use existing Network assets to create NNI links to URSA
- URSA beyond the reach of existing assets can be reached with purchase of Telecom Wholesale Data Services;

- CBR

- VBR

- UBR

Available as 2,4,8,16,32,64,128,155Mbit/sec links

- Telecom Flexible Backhaul Service – Option 2

- TCL decide number of NNI(s), pay for backhaul on a customer by distance basis
 - Telecom manages bandwidth/geographic distribution risk therefore a throughput charge is levied if the average allowance (10GB) per connection is exceeded.



Glossary



URSA – UBS Regional Service Area, being the geographic area serviced by a given USAP. An URSA will contain numerous DSLAMs

USAP – Unbundled Service Aggregation Point, being a Telecom ATM data switch or equivalent facility other than a DSLAM. This is the point within a URSA where all UBS traffic within that URSA is aggregated for handover to a Service Provider

NNI – Network to Network Interface, typically an access used to facilitate a data interconnect link between data networks.

UNI – User Network Interface, typically a commercial access sold to customer to facilitate the transmission of commercial data services to the customer site.

CBR – Committed Bit Rate

VBR – Variable Bit Rate

UBR – Unspecified Bit Rate

UPC – Unbundled Partial Circuit

UBS – Unbundled Bitstream Service

DSLAM – Digital Subscriber Line Access Multiplexer, the data switch that the end-user premises is connected to in order to provide the UBS service.

