

**NEW ZEALAND**

**COPPER LOCAL LOOP**

**INTERFERENCE MANAGEMENT PLAN**

**PART 2**

**SPECTRAL COMPATIBILITY DETERMINATION PROCESS**

**JUNE 2008 – FINAL CONSULATION DRAFT**

# CONTENTS

CONTENTS .....	2
1 INTRODUCTION AND OVERVIEW.....	1
1.1 Introduction.....	1
1.2 Overview .....	1
2 SPECTRAL COMPATIBILITY DETERMINATION PROCESS.....	3
2.1 Definition of Spectral Compatibility Determination Process.....	3
2.2 Definition of Spectral Compatibility Benchmark and Basis System.....	3
2.3 Unacceptable Interference into a Basis System.....	4
2.4 Unacceptable Excess Power .....	8
3 PROCESS FOR ASSESSMENT OF NON-DEPLOYMENT CLASS SYSTEMS.....	11
4 PROCESS FOR DETERMINATION OF SPECTRAL COMPATIBILITY BENCHMARKS FOR BASIS SYSTEMS AND DEPLOYMENT RULES FOR DEPLOYMENT CLASS SYSTEMS.....	13
4.1 Spectral Compatibility Benchmark I Determination .....	13
4.2 Spectral Compatibility Benchmark II Determination .....	19
5 CALCULATION OF BASIS SYSTEM PERFORMANCE .....	26
5.1 Cable Environment .....	26
5.2 The Noise Environment .....	26
5.3 Transceiver Models for Basis Systems .....	28
6 EXPECTED WORST CASE WIDEBAND NOISE MASK BELOW 2.208MHz ON THE MPF .....	33
7 REFERENCES.....	35
APPENDIX A TRANSMIT PSD TEMPLATES FOR DEPLOYMENT CLASS SYSTEMS .....	36

# 1 INTRODUCTION AND OVERVIEW

## 1.1 Introduction

Part 2 describes the Spectral Compatibility Determination Process together with the assumptions and analytical techniques required to assess system spectral compatibility.

The Spectral Compatibility Determination Process is the process that determines matters pertaining to spectral compatibility of Disturbing and Disturbed Systems used on distinct unconditioned Communications Wires. Elements of the process include determining the Spectral Compatibility Benchmarks of Basis Systems, Unacceptable Interference into a Basis System, and Unacceptable Excess Power.

Part 1 of this IMP requires that Service Providers that propose to deploy a system that is not within a Deployment Class use the Spectral Compatibility Determination Process to determine whether or not the proposed system causes either Unacceptable Interference into a Basis System or Unacceptable Excess Power. A computer model based on this process has been developed by Telstra Australia for the Australian Interference management standard C559. The existing ACIF tool will be used for the Spectral Compatibility Determination Process under this IMP until the ACIF tool is adapted and adopted for the New Zealand metallic path copper network or a new tool is developed.

The Spectral Compatibility Benchmarks for Basis Systems are set out in Clauses 4.1.1 and 4.2.1 of Part 2 of this IMP, Unacceptable Interference into a Basis System is addressed in Clause 2.3 of Part 2 of this IMP, and Unacceptable Excess Power is addressed in Clause 2.4 of Part 2 of this IMP.

## 1.2 Overview

It is well known that in the unshielded twisted pair cable used to provide local loops, xDSL signals on one twisted pair cause interference to signals on other twisted pairs in the same cable. This interference, called crosstalk, is caused by electromagnetic coupling between the unshielded twisted pairs and has the potential to unacceptably degrade the performance of services/systems sharing the same cable, thereby compromising network integrity.

In an unbundled loop environment, where Telecom's local loop cable is being shared by Service Providers, inter-system crosstalk must be controlled to ensure an acceptable level of protection of network integrity. Therefore, in order to ensure effective exploitation of the unbundled local loop, there is a requirement for Service Providers to abide by a set of agreed performance requirements by suitable selection of the type, quantity and disposition of xDSL systems to ensure their spectral compatibility.

Crosstalk depends on pair-to-pair exposure, signal frequency and signal strength.

Pair-to-pair exposure depends on the length variation of proximity of pairs in a cable and crosstalk coupling increases with increasing proximity and cable length. Unavoidable variability in cable manufacturing processes leads to unavoidable variability in exposure between cable pairs and it is impossible to specify/predict the exact amount of crosstalk between pairs in a cable. In addition, the level of interference is increased by any imbalance in the equipment and this is controlled by appropriate specification of equipment longitudinal balance similar to the intrinsic cable pair longitudinal balance.

Crosstalk coupling is very sensitive to exposure and the variability/unpredictability of crosstalk interference dominates all other system variability, and an extreme worst-case design cannot be economically justified.

This leads to the unavoidable use of statistical measures and techniques to determine performance requirements for the operation of systems that use the MPF. The statistical techniques are based on the underlying assumption that Telecom makes available to the

Service Provider cable pairs chosen at random from a population of cable pairs that exhibit no unusual or 'faulty' performance. In other words, it is assumed that cable pairs exhibit typical transmission and crosstalk performance variability consistent with typical cable manufacturing and installation processes. As mentioned above, an extreme worst case design which ensures that all such typical pairs can be used for Unconditioned Local Loop Service cannot be economically justified, and so the performance requirements for operation of systems using MPFs are based on assuming that less than 1% of typical pairs offered to a Service Provider exhibit excessive crosstalk.

With the expectation that less than 1% of offered pairs prove unsuitable, there is little benefit in requiring any pre-qualification of offered pairs. Rather, offered pairs need only be tested by the Service Provider when excessive crosstalk is suspected.

High frequency energy has higher coupling than lower frequency energy because crosstalk increases with frequency. Thus the higher the speed/capacity of the xDSL system, the greater the potential for inter-system interference. Crosstalk is directly proportional to signal strength, so limiting transmit power lessens inter-service interference. Hence, controlling the spectral content and balance of xDSL signals through specifying transmit signal spectral masks and equipment longitudinal balance, and controlling the number and disposition of xDSL systems in a cable are effective means of limiting crosstalk interference between systems.

## 2 SPECTRAL COMPATIBILITY DETERMINATION PROCESS

### 2.1 Definition of Spectral Compatibility Determination Process

The **Spectral Compatibility Determination Process** is the process that determines matters pertaining to spectral compatibility of Disturbing and Disturbed Systems used on the MPF. Elements of the process include the determination of Unacceptable Interference into a Basis System, the determination of Unacceptable Excess Power, and the process for determination of Spectral Compatibility Benchmarks for Basis Systems and Deployment Rules for Deployment Class Systems.

### 2.2 Definition of Spectral Compatibility Benchmark and Basis System

A **Spectral Compatibility Benchmark** is the determined relationship between system bit rates achievable by a Basis System in each direction and system deployment range (expressed as a single deployment range for a fixed rate system) for a system error rate of  $10^{-7}$  with margin of 6dB in the 1% worst-case crosstalk environment.

*NOTE 1: The 1% worst case-crosstalk environment is defined in Clause 5.2 of Part 2 of this IMP.*

*NOTE 2: The Spectral Compatibility Benchmark includes the rates in each direction of transmission. For a fixed rate system, the Spectral Compatibility Benchmark is the system range which achieves the required rate in both directions with at least 6 dB margin.*

A **Basis System** is a system type that has one or more determined Spectral Compatibility Benchmarks or fully complies with a Basis Systems Deployment Class where no Compatibility Benchmarks are provided.

The Basis Systems used in this IMP are set out in Table 2-1 of Part 2 of this IMP and their Spectral Compatibility Benchmarks are given in Clauses 4.1.1 and 4.2.1 of Part 2 of this IMP.

*NOTE 1: Both transmitter and receiver performance of a Basis System are required to determine its Spectral Compatibility Benchmark.*

*NOTE 2: Some, but not all, Legacy Systems are Basis Systems.*

*NOTE 3: Basis Systems and the associated Spectral Compatibility Benchmarks for different network topologies provide the basis for ensuring network integrity.*

*NOTE 4: Deployment Classes are defined in Part 3, including those for Basis Systems. Refer to Table A-1 in Part 3 of this IMP for the list of Deployment Classes.*

Name	Description	Relevant Standard
Voiceband		
ISDN-BR	2B1Q	ITU-T G.961
E1-HDB3	2048 kbit/s	ITU-T G.703
ADSL1	Reduced NEXT option	ITU-T G.992.1
ADSL2+	Non-overlapped spectrum mode	ITU-T G.992.5
SHDSL 576kbit/s	16-TCPAM, $f_{sym}=194.67$	ITU-T G.991.2 and Annex B
SHDSL 1160 kbit/s	16-TCPAM, $f_{sym}=389.33$	ITU-T G.991.2 and Annex B
SHDSL 2312 kbit/s	16-TCPAM, $f_{sym}=773.33$	ITU-T G.991.2 and Annex B
ESHDSL 3840 kbit/s	16-TCPAM, $f_{sym}=1282.67$	ITU-T G.991.2 and Annex F
ESHDSL 5696 kbit/s (Note 1)	32-TCPAM, $f_{sym}=1426$	ITU-T G.991.2 and Annex F
VDSL2	997 band plan	ITU-T G993.2 and Annex B including Amendment 1 (04/2007)

**TABLE 2-1**

### Basis Systems

*NOTE 1: Only 4 bits/symbol (32-TCPAM) available at this data rate in ITU-T Recommendation G991.2.*

*Note 2: VDSL2 does not have a specific spectral capability Benchmark. Conformance is only required to the Deployment Class for VDSL2 in Part 3 of this IMP. However the performance should not be less than the equivalent ADSL2+ configuration used below 2.208MHz.*

Transceiver models for those Basis Systems that have Spectral Compatibility Benchmarks are given in Clause 5.3 of Part 2 of this IMP.

## 2.3 Unacceptable Interference into a Basis System

**Unacceptable Interference into a Basis System** is defined in Clause 8.2.2 of Part 1 of this IMP. The concept of Unacceptable Interference into a Basis System requires determination of the impact on Basis Systems of crosstalk interference caused by disturbing systems. The impact on Basis Systems is determined as follows:

1. The determination of crosstalk interference is based on a representative cable sub-unit consisting of 25 twisted pairs, 10 of which carry the disturbing system and 11 of which carry the disturbed system type. Hence each disturbed system is subject to interference from 10 systems of the disturbing type and 10 of the same type as itself.
2. The method of calculation of the 1% worst-case crosstalk from the disturbing systems is given in Clause 5 of Part 2 of this IMP.
3. The transmit and receive characteristics of the Basis Systems are given in Clause 5.3 of Part 2 of this IMP
4. The topologies considered in the determination must include all those permissible within the deployment restrictions for the disturbing system.

5. The level of interference depends on the relative disposition of disturbing and disturbed systems, and in particular, to represent system performance differences between Deployment State A and Deployment State B, two Spectral Compatibility Benchmarks are defined for each Spectrally Asymmetric Basis System. Spectral Compatibility Benchmark I applies to Basis Systems fed from the Highest NRP in Deployment State A and from the Nominated Lower NRP in Deployment State B, whilst Spectral Compatibility Benchmark II applies to Basis Systems fed from the Highest NRP in Deployment State B.

#### 2.3.1 Test for Crosstalk Interference

For all configurations listed below, the performance of all Basis System types as defined in Clause 5.3 of Part 2 of this IMP must be no worse than the applicable Spectral Compatibility Benchmarks of those Basis Systems as given in Clauses 4.1.1 and 4.2.1 of Part 2 of this IMP.

The spectral compatibility calculations specified in this clause are based on the assumptions of Clause 2.3 of Part 2 of this IMP and the method of calculation of Basis System performance given in Clause 5 of Part 2 of this IMP with the following configurations of the proposed system interfering into each Basis System type in turn.

*NOTE 1: Different configurations are required for each direction of the Spectral Compatibility Benchmark I;*

*NOTE 2: In each direction the Spectral Compatibility Benchmark is a function of the range of the disturbed Basis System from its Deployment Reference Point (usually at the Highest NRP).*

The process for determining proposed deployment rules based on the requirement of Unacceptable Interference into a Basis System is given in Clause 3 of Part 2 of this IMP for Non-Deployment Class Systems and in Clause 4 of Part 2 of this IMP for Deployment Class Systems.

##### (a) Spectral Compatibility Benchmark I configuration.

The configurations in Figures 2-1 and 2-2 of Part 2 of this IMP for determination of the downstream Spectral Compatibility Benchmark I consist of 10 interferers of the proposed type fed from the proposed Lowest Asymmetric System Feed Point and with the customer end at the higher (or shorter range from the highest NRP) of:

- (i) the same location as the disturbed Basis System, or
- (ii) a point at the proposed Deployment Limit below the Deployment Reference Point.

and 10 interferers of the same type and the same Deployment Class Nominal PSD as the Basis System, with both ends co-located with the disturbed Basis System, interfering into the Basis System fed from the Highest NRP.

The configuration in Figure 2-3 for determination of the upstream Spectral Compatibility Benchmark I consists of 10 interferers of the proposed type and 10 interferers of the same type and the same Deployment Class Nominal PSD as the disturbed Basis System, with both ends co-located with the disturbed Basis System, interfering into the Basis System fed from the Highest NRP.

In both of these configurations the performance must be equal to or better than the corresponding Spectral Compatibility Benchmark I in Clause 4.1.1 of Part 2 of this IMP for the relevant direction.

- (b) Spectral Compatibility Benchmark II configuration (Deployment State B - only for Spectrally Asymmetric Basis Systems)

Spectral Compatibility Benchmark II is defined only for the downstream direction and only for Basis System range beyond the specified range to the Nominated Lower NRP.

The configuration in Figure 2-4 of Part 2 of this IMP for determination of the downstream Spectral Compatibility Benchmark I consists of 10 asymmetric interferers of the proposed type fed from the proposed Lowest Asymmetric System Feed Point and with the customer end at the higher of:

- (i) the same location as the disturbed Basis System, or
- (ii) a point at the proposed Deployment Limit below the Deployment Reference Point.

and 10 interferers of the same asymmetric type and same Deployment Class Nominal PSD as the Basis System fed from the Nominated Lower NRP, interfering into the Basis System fed from the Highest NRP. This should be repeated for 0.5 km intervals between 0.5 km and 3 km of the range from the Highest NRP to the Nominated Lower NRP.

In this configuration the performance must be equal to or better than the corresponding Spectral Compatibility Benchmarks II in Clause 4.2.1 of Part 2 of this IMP with the specified range parameter.

*NOTE: Lowest Asymmetric System Feed Point is the point nominated as per Clause 8.4.4(6) in Part 1 of this IMP.*

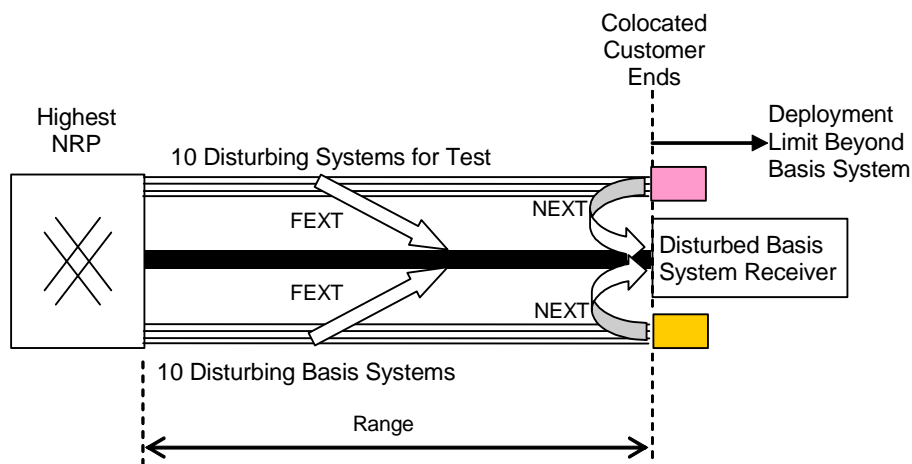

**FIGURE 2-1:**

**Configuration for Downstream Benchmark I for Basis System ranges up to the proposed Deployment Limit**

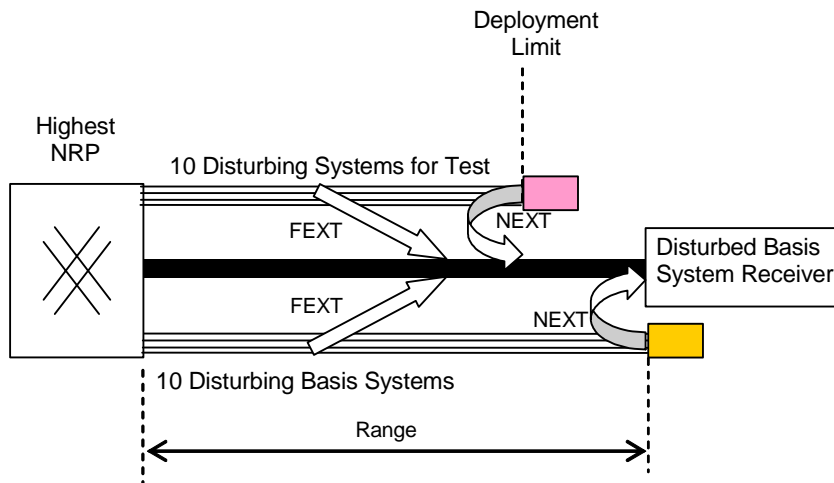

**FIGURE 2-2**

**Configuration for Downstream Benchmark I for Basis System ranges beyond the proposed Deployment Limit**

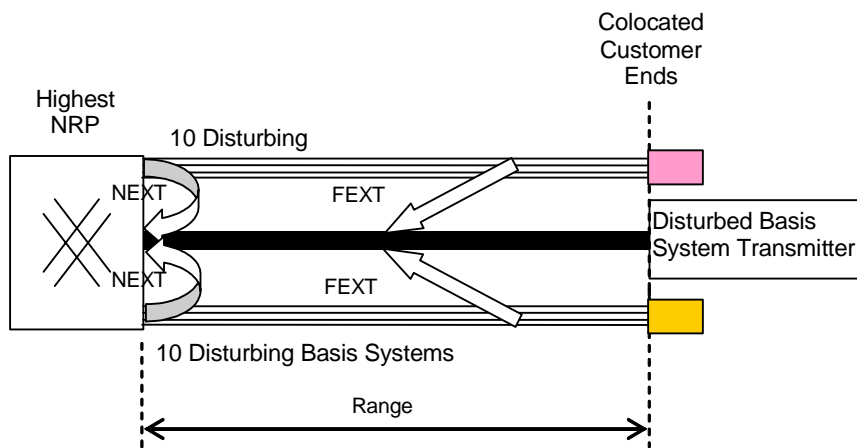

**FIGURE 2-3**

**Configuration for Upstream Benchmark I**

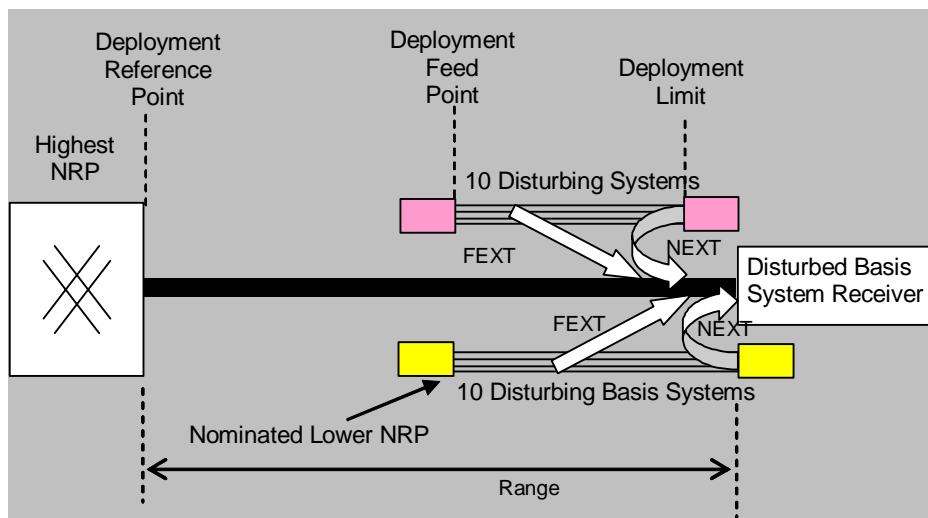

## **Configuration for Benchmark II (Downstream only) for Asymmetric Basis Systems operating below 2.208MHz.**

*NOTE 1: The Deployment Reference Point and Lowest Asymmetric Feed Point may be nominated by the Service Provider; the Deployment Limit shown is based on the limit for Deployment State A and is measured from the proposed Deployment Reference Point.*

*NOTE 2: This diagram only shows the case in Clause 2.3.1 (b) (ii) of Part 2 of this IMP.*

### 2.3.2 Tests for Longitudinal Balance and Signal Levels

For Non-Deployment Class Systems, the longitudinal output voltage masks of Clause 8.4.4(7) of Part 1 of this IMP and the longitudinal balance masks specified of Clause 8.4.4(8) of Part 1 of this IMP are required to be within the limits below at all frequencies in the specified frequency ranges.

- (a) Longitudinal output voltage limit:  
-50dBV in any 4kHz band over a frequency range of 10kHz to 12040kHz
- (b) Longitudinal balance limit:  
40dB from 20kHz to f kHz with a slope 20dB/decade below 20kHz and -20dB/decade above f.

The value of f is the highest frequency in kHz at which the PSD mask is 20dB below its peak .

Where the system uses a different PSD in each direction, the frequency of the upper breakpoint for longitudinal balance is the same for both ends of the system and is the maximum determined from either end PSD.

For Deployment Class Systems, the longitudinal output voltage and balance masks are referenced in Part 3 of this IMP.

## 2.4 Unacceptable Excess Power

Clause 8.2.1 of Part 1 of this IMP requires a Non Deployment Class System not to cause **Unacceptable Excess Power**. Excess power is a measure of the amount by which the system transmit PSD exceeds the maximum PSD of all Deployment Class Systems in Part 3 of this IMP, as shown in Clause 2.4.1 of this IMP.

- 2.4.1 Define the Unacceptable Excess Power Template U(f) as the maximum over all of the transmit PSD templates in mW/Hz of all Deployment Class Systems.

$$U(f) = \text{Max} \{P_i(f)\}$$

where  $P_i(f)$  are the Nominal PSD transmit templates of the Deployment Class systems in both directions.

The function  $10 \log_{10}(U(f))$  in dBm/Hz is given in Table 2-2 of Part 2 of this IMP and plotted in Figure 2-5 of Part 2 of this IMP.

Define the function:

$$POS(X) = \begin{cases} X, & X \geq 0 \\ 0, & X < 0 \end{cases}$$

For a proposed system with transmit PSD S(f) mW/Hz, the excess power is given by:

$$\text{Excess power} = \int_0^{\infty} POS(S(f) - U(f))df$$

2.4.2 The system does not cause Unacceptable Excess Power if Excess power  $\leq 0.05$  mW.

Centre Freq, KHz	Limiting Technology		UEP $10\log_{10}\{U(f)\}$	Centre Freq, KHz	Limiting Technology		UEP $10\log_{10}\{U(f)\}$
5	Class 4a	Basic ISDN	-32.5	1850	Class 6h	ADSL 2+	-50.5
50	Class 4a	Basic ISDN	-35.6	1900	Class 6h	ADSL 2+	-50.7
100	Class 6g	READSL	-36.4	1950	Class 6h	ADSL 2+	-50.8
150	Class 6c	ADSL/ISDN	-38.0	2000	Class 6h	ADSL 2+	-50.9
200	Class 6c	ADSL/ISDN	-38.0	2050	Class 6h	ADSL 2+	-51.0
250	Class 6g	READSL	-37.6	2100	Class 6h	ADSL 2+	-51.1
300-550	Class 6g	READSL	-37.0	2150	Class 6h	ADSL 2+	-51.2
600-1100	Class 6g	ADSL FD	-40	2200	Class 6h	ADSL 2+	-51.3
1200	Class 6g	ADSL FD	-42.2	2500	Class 10	VDSL2	-52.1
1250	Class 6h	ADSL 2+	-43.2	3000	Class 10	VDSL2	-53.8
1300	Class 6h	ADSL 2+	-44.3	4000	Class 10	VDSL2	-55
1350	Class 6h	ADSL 2+	-45.3	5000	Class 10	VDSL2	-56.0
1400	Class 6h	ADSL 2+	-46.2	6000	Class 10	VDSL2	-56.8
1450	Class 6h	ADSL 2+	-47.1	7050	Class 10	VDSL2	-57.5
1500	Class 6h	ADSL 2+	-47.9	8000	Class 10	VDSL2	-58
1550	Class 6h	ADSL 2+	-48.8	10000	Class 10	VDSL2	-58.9
1600	Class 6h	ADSL 2+	-49.7	12000	Class 10	VDSL2	-59
1650	Class 6h	ADSL 2+	-50.1	14000	Class 10	VDSL2	-60
1700	Class 6h	ADSL 2+	-50.2	20000	Class 10	VDSL2	-60
1750	Class 6h	ADSL 2+	-50.3	25000	Class 10	VDSL2	-60
1800	Class 6h	ADSL 2+	-50.4	30000	Class 10	VDSL2	-60

**TABLE 2-2**  
**Unacceptable Excess Power Template**

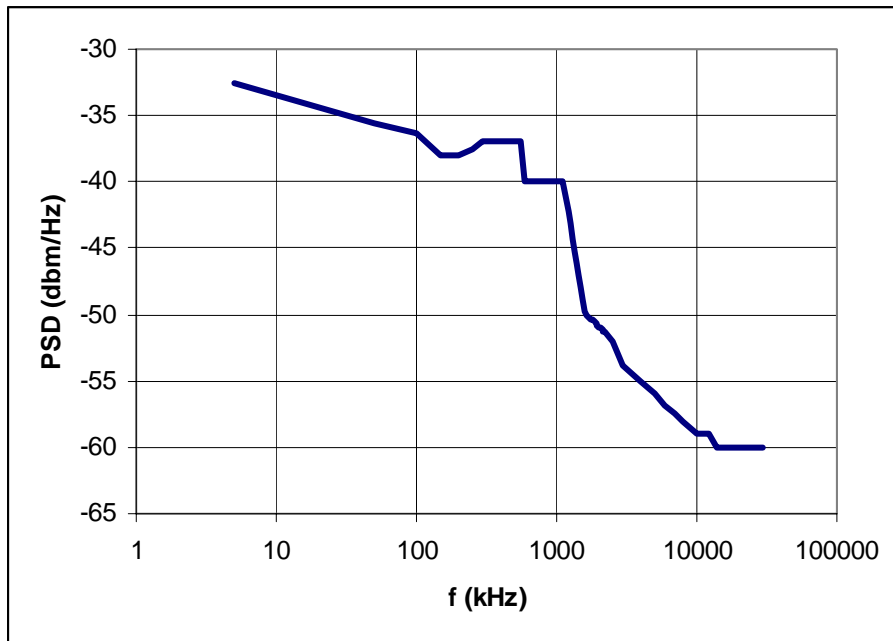

**FIGURE 2-5**  
**Unacceptable Excess Power Template**

### 3 PROCESS FOR ASSESSMENT OF NON-DEPLOYMENT CLASS SYSTEMS

All systems operated using the MPF must not cause Unacceptable Interference into a Basis System. Clause 8.4 of Part 1 of this IMP requires a Service Provider proposing to operate a Non-Deployment Class system to use the Spectral Compatibility Determination Process described below to determine whether the system will cause Unacceptable Interference into a Basis System.

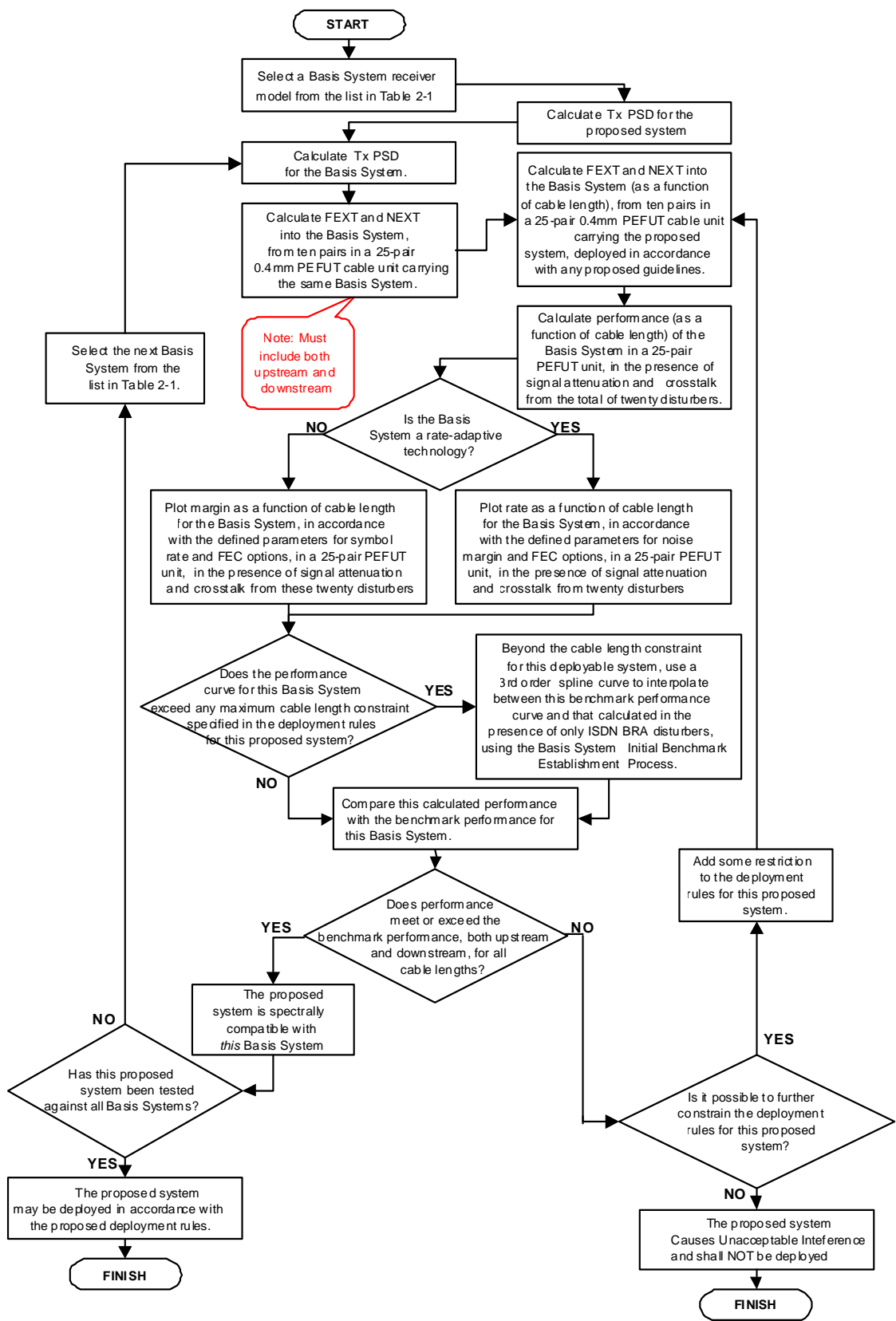

**FIGURE 3-1**

**Process for Assessment of Non-Deployment Class Systems**

*NOTE: If the proposed Deployment Class System has a minimum cable length constraint then calculations for shorter lengths than the Deployment Limit are not required*

## 4 PROCESS FOR DETERMINATION OF SPECTRAL COMPATIBILITY BENCHMARKS FOR BASIS SYSTEMS AND DEPLOYMENT RULES FOR DEPLOYMENT CLASS SYSTEMS.

The Spectral Compatibility Benchmarks have been determined for a set of idealised Basis Systems that operate below 2.208MHz and are representative of the system types used on the MPF. The Spectral Compatibility Benchmarks provide a metric against which the interference generated by proposed deployments is assessed. The crosstalk from 10 systems from a Deployment Class, together with 10 systems of the same type as the Basis System, must not degrade the performance of the Basis System below its Spectral Compatibility Benchmark.

*NOTE: The 10 systems from a Deployment Class referred to above may be the same as the Basis System.*

A consistent set of Deployment Classes and Spectral Compatibility Benchmarks is achieved by taking into account the trade-off between suitable Deployment Rules for each Deployment Class and realistic Spectral Compatibility Benchmarks.

Because this IMP defines two Deployment States A and B for a DA, two Spectral Compatibility Benchmarks and multiple configurations must be considered in determining whether the operation of a system will cause Unacceptable Interference into a Basis System. These configurations are given in Clause 2.3.1 of Part 2 of this IMP.

Spectral Compatibility Benchmark I is used to determine the Deployment Rules in Deployment State A.

In Deployment State B, any of the above derived State A Deployment Limits apply, but the Deployment Reference Point from which each limit is measured may differ. For Basis Systems deployed from the Nominated Lower NRP in Deployment State B, the Spectral Compatibility Benchmark I performance is used. However for Basis Systems deployed from any higher NRP in Deployment State B, the Spectral Compatibility Benchmark is degraded by an amount dependent on the range from that higher NRP to the Nominated Lower NRP. Spectral Compatibility Benchmark II gives that performance with the range as a parameter.

### 4.1 Spectral Compatibility Benchmark I Determination

This process and the resulting Spectral Compatibility Benchmark I applies to Basis Systems originating from the Highest NRP when the DA is in Deployment State A, and to Basis Systems originating from the Nominated Lower NRP when the DA is in Deployment State B. In these situations the Basis Systems achieve their best possible Spectral Compatibility Benchmark in the presence of other systems. (Note that in Deployment State B, a Spectrally Asymmetric Basis System deployed from the Highest NRP will suffer degraded performance compared with Spectral Compatibility Benchmark I; an additional Spectral Compatibility Benchmark II for these cases is included in Clause 4.2 of Part 2 of this IMP.)

The process for determining whether or not a system is deployable is shown in Figure 4-1 of Part 2 of this IMP and the process for reviewing the Spectral Compatibility Benchmark I of a Basis System is shown in Figure 4-2 and Figure 4-3 of Part 2 of this IMP.

Analysis techniques, assumptions and transceiver models for Basis Systems are shown in Clause 5 of Part 2 of this IMP.

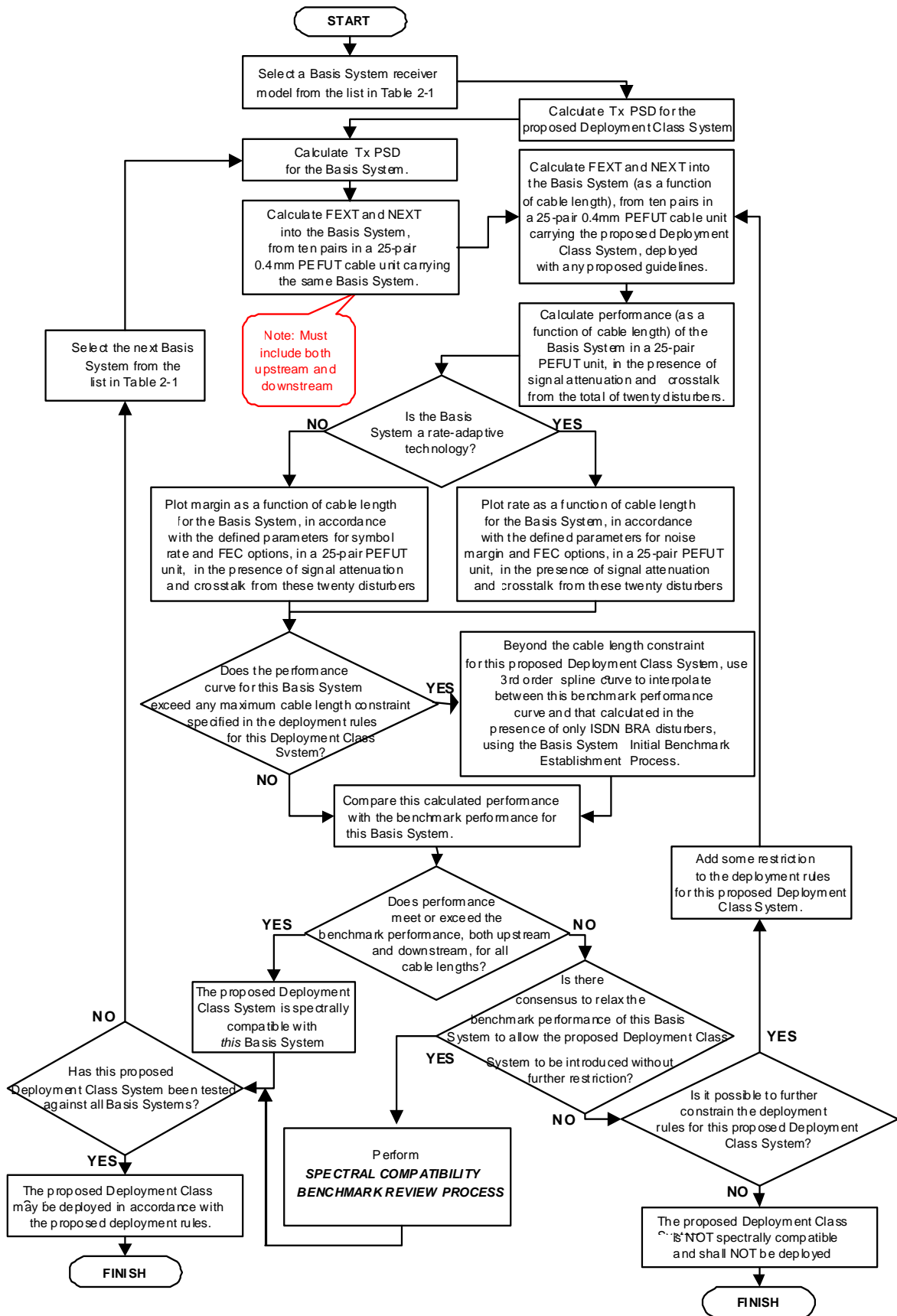
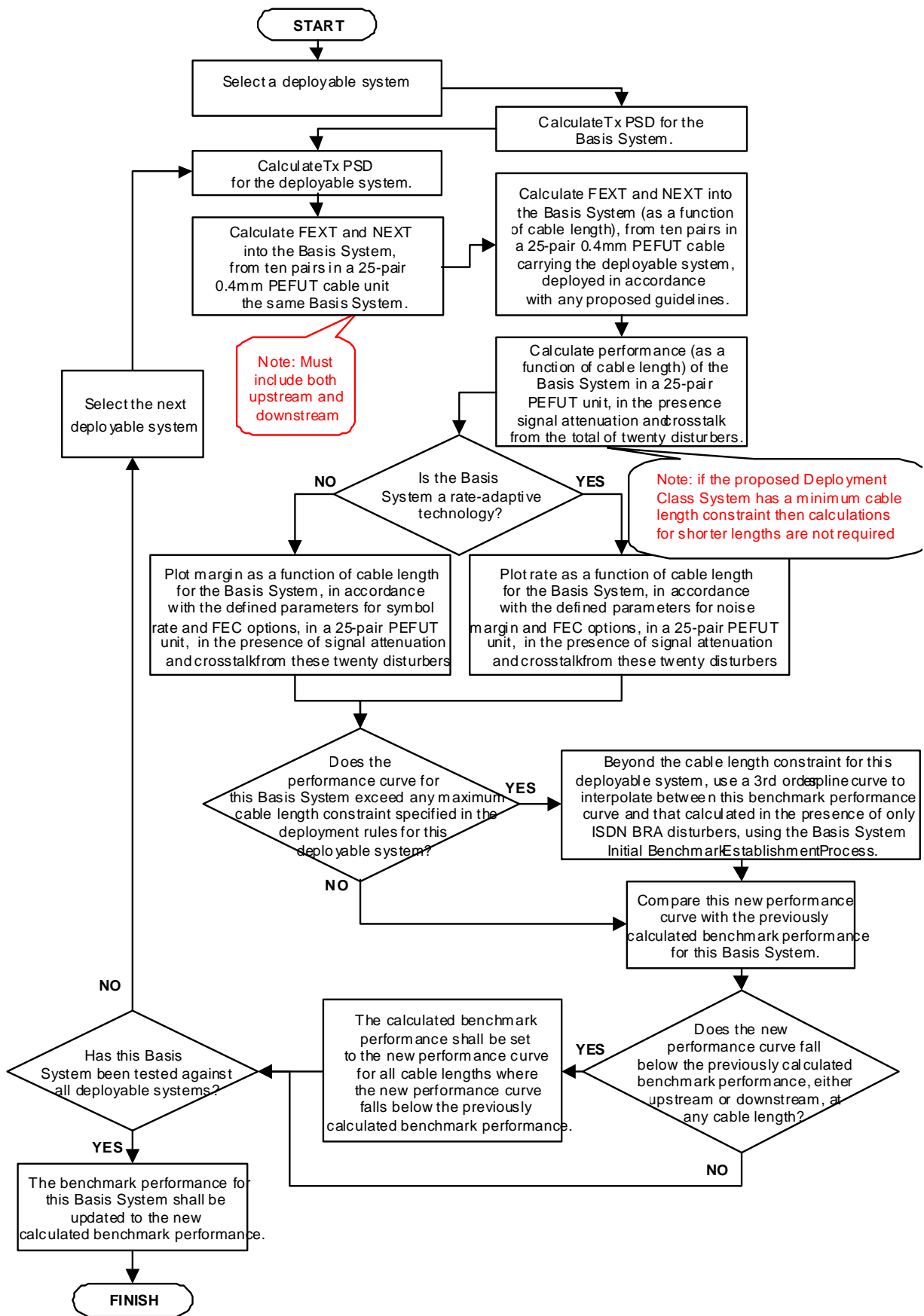

FIGURE 4-1

Deployment Class System Deployment Rule Determination



**FIGURE 4-2**  
**Spectral Compatibility Benchmark Review**

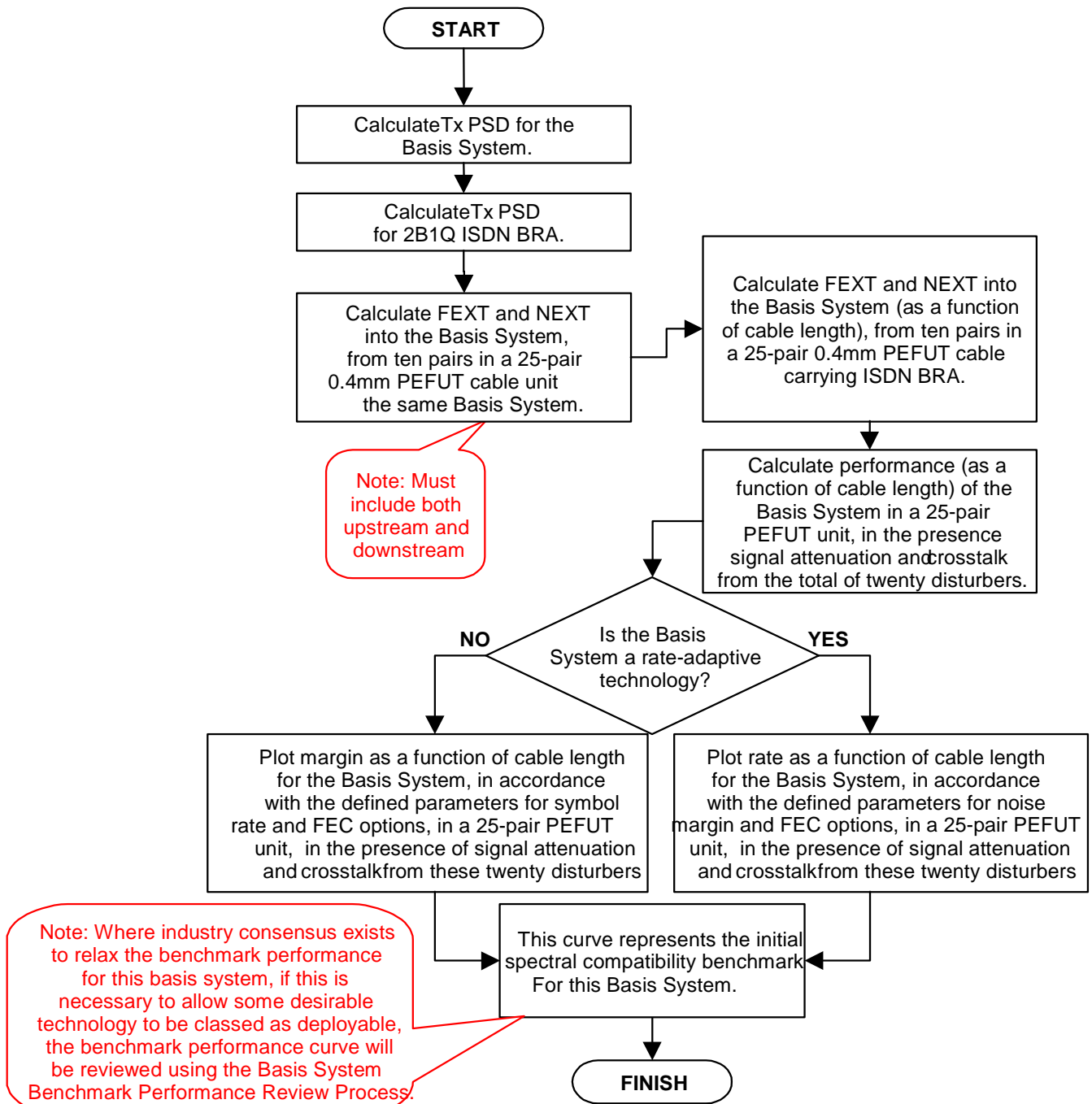

FIGURE 4-3

### Initial Spectral Compatibility Benchmark Establishment

#### 4.1.1 Spectral Compatibility Benchmark I

Spectral Compatibility Benchmarks I have been determined for the Basis Systems described in Clause 5.3 of Part 2 of this IMP.

The Spectral Compatibility Benchmark I for the Voiceband Basis System is the requirement that the total power of any disturbing system in the frequency band  $0 < f \leq 4\text{kHz}$  shall be less than  $-9\text{dBm}$  ( $600\Omega$ ).

The Spectral Compatibility Benchmarks I for the fixed rate Basis Systems are given in Table 4-1 of Part 2 of this IMP both as ranges and as attenuations at the relevant reference frequency (half of the baud rate) in each case.

System	Range (km of 0.4mm PEFUT)	Reference frequency (kHz)	Indicative Attenuation (dB at Reference Frequency)
ISDN-BR	6.2	40	40
E1-HDB3	0.7	1024	15
SHDSL 576(C-16) kbit/s	4.6	160	44
SHDSL 1160(C-16) kbit/s	3.4	160	32
SHDSL 2312(C-16) kbit/s	2.1	160	20
ESHDSL 3840(C-16) kbit/s	1.4	160	13
ESHDSL 5696(C-32) kbit/s	0.7	160	7

**TABLE 4-1**

**Spectral Compatibility Benchmark I for Fixed Rate Systems, operating on 0.4mm PEFUT cable**

The Spectral Compatibility Benchmarks I of the variable rate systems are given in Table 4-2 of Part 2 of this IMP and in Figure 4-4 of Part 2 of this IMP as the net payload rate with 6 dB margin versus attenuation at 160 kHz. Note that these Spectral Compatibility Benchmarks have been determined for transceivers operating on well-matched and well-balanced lines; i.e. with no impact from splitters.

		ADSL		ADSL2+				ADSL		ADSL2+	
Range	Atten(dB)	Rate (kbit/s)		Rate (kbit/s)		Range	Atten(dB)	Rate (kbit/s)		Rate (kbit/s)	
(km)	at160kHz	down	up	down	up	(km)	at160kHz	down	up	down	up
0.1	0.95	7616	832	21117	1344	2.6	24.7	5327	787	8095	827
0.2	1.9	7616	832	19281	1344	2.7	25.65	5273	762	7596	802
0.3	2.85	7616	832	18191	1336	2.8	26.6	5204	737	7174	777
0.4	3.8	7616	832	17408	1318	2.9	27.55	5118	712	6785	752
0.5	4.75	7616	832	16794	1301	3	28.5	5009	687	6422	727
0.6	5.7	7616	832	16286	1282	3.1	29.45	4858	662	6108	702
0.7	6.65	7616	832	15852	1264	3.2	30.4	4683	636	5786	676
0.8	7.6	7616	832	15471	1245	3.3	31.35	4487	611	5468	651
0.9	8.55	7342	832	15130	1225	3.4	32.3	4212	585	5158	625
1	9.5	7048	832	14820	1205	3.5	33.25	3917	560	4858	600
1.1	10.45	6744	832	14406	1184	3.6	34.2	3646	534	4567	574
1.2	11.4	6429	832	13957	1163	3.7	35.15	3397	509	4279	549
1.3	12.35	6100	832	13501	1140	3.8	36.1	3161	483	3997	523
1.4	13.3	5756	832	13033	1117	3.9	37.05	2954	458	3733	498
1.5	14.25	5617	832	12774	1094	4	38	2749	432	3483	472
1.6	15.2	5593	832	12624	1071	4.1	38.95	2561	407	3263	447
1.7	16.15	5570	832	12453	1047	4.2	39.9	2375	374	3032	421
1.8	17.1	5548	832	12246	1023	4.3	40.85	2191	342	2817	395
1.9	18.05	5526	832	11979	999	4.4	41.8	2010	304	2604	370
2	19	5504	832	11635	975	4.5	42.75	1852	267	2412	344
2.1	19.95	5482	832	11200	951	4.6	43.7	1675	241	2226	319
2.2	20.9	5459	832	10672	926	4.7	44.65	1505	201	2062	290
2.3	21.85	5433	832	9931	902	4.8	45.6	1357	161	1892	259
2.4	22.5	5404	832	9305	877	4.9	46.55	1208	140	1721	233
2.5	23.75	5370	812	8659	852	5	47.5	1081	119	1532	205

**TABLE 4-2**

**Spectral Compatibility Benchmark I values for Variable Rate Systems, operating on 0.4mm PEFUT cable.**

*NOTE: At short ranges the actual calculated net transmission rates exhibit step fluctuations caused by the mandatory power cut-back provisions for ADSL and ADSL2/ADSL2+ systems, specified in Table C-2 of Part 3 of this IMP. These fluctuations have been removed by setting constant rates (equal to the lowest local minima) across this region of the table for ADSL.*

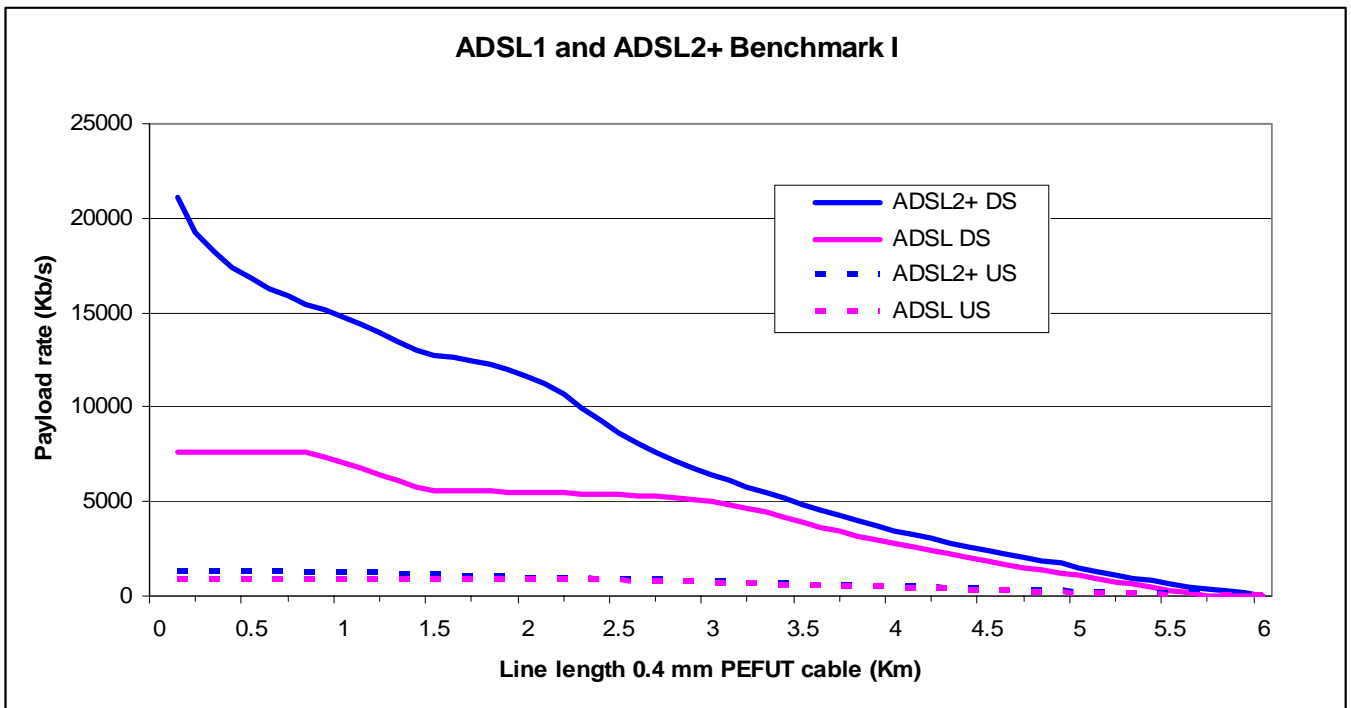

**FIGURE 4-4**

**Spectral Compatibility Benchmark I values for Variable Rate Systems, operating on 0.4mm PEFUT cable**

**4.2 Spectral Compatibility Benchmark II Determination**

Spectral Compatibility Benchmark II applies to Spectrally Asymmetric Basis Systems originating from any NRP higher than the Nominated Lower NRP when the DA is in Deployment State B. Those Basis systems unavoidably suffer degraded performance as a result of unequal level FEXT from other Spectrally Asymmetric systems which may be deployed from lower NRPs in Deployment State B. These Spectral Compatibility Benchmarks II have been generated in order to determine which systems may be deployed from the Nominated Lower NRP in Deployment State B, without further degrading the performance of Spectrally Asymmetric Basis Systems originating from the Highest NRP. Because the use of symmetric systems from the Highest NRP does not result in failure to achieve the Spectral Compatibility Benchmarks I performance of those systems, these Spectral Compatibility Benchmarks II apply only to Spectrally Asymmetric Basis Systems.

The process of determination of the Spectral Compatibility Benchmark II uses the processes in Figs 4-1 to 4-3 with the following modifications:

1. Only the performance of Spectrally Asymmetric Basis Systems operating from the Highest NRP in Deployment State B are considered.
2. A separate Spectral Compatibility Benchmark II performance is established for each of a range of lengths on 0.4mm PEFUT cable from the Highest NRP to the Nominated Lower NRP at which the disturbing systems are fed.
3. The process of establishing the Spectral Compatibility Benchmark II curves must not result in any change to the Deployment Limits, but may result in a change in the location of the Lowest Asymmetric Feed Point and the Deployment Reference Point for some Deployment Classes in Deployment State B.

4.2.1 Spectral Compatibility Benchmark II

The Spectral Compatibility Benchmark II of the Spectrally Asymmetric Basis Systems when fed from the Highest NRP in Deployment State B are given in Table 4-3 of Part 2 of this IMP for ADSL and Table 4-4 of Part 2 of this IMP for ADSL2+. In each case the Spectral Compatibility Benchmark II is a function of the range from the Highest NRP to the Nominated Lower NRP for Deployment State B.

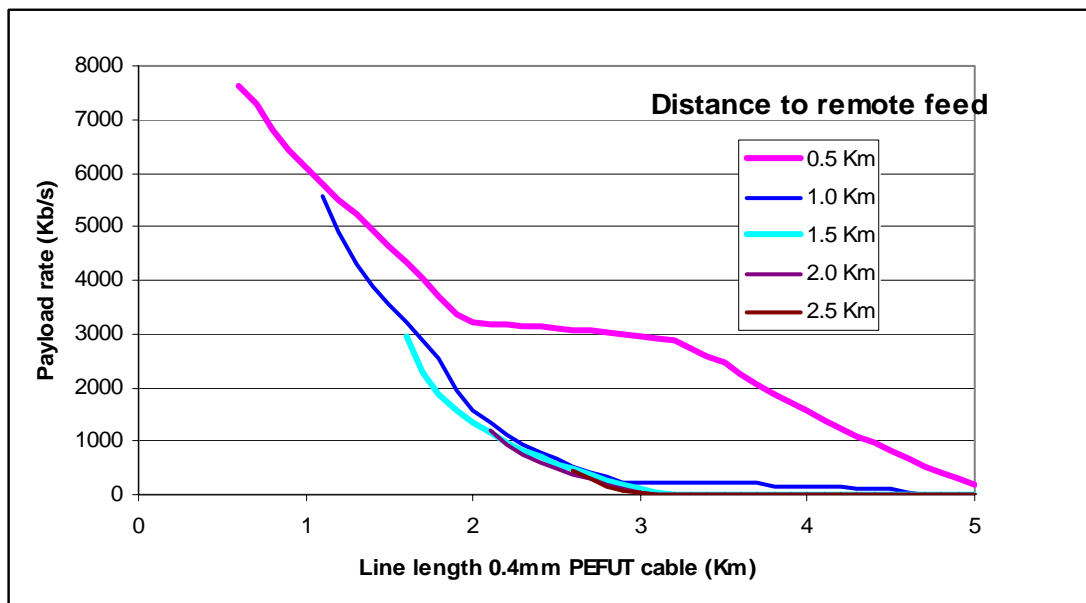

**FIGURE 4-5**

Spectral Compatibility Benchmark II values for ADSL as a function of range from the Highest NRP, with range from the Highest NRP to the Nominated Lower NRP as a parameter.

Range		Attenuation at 160 kHz to remote feed (Dist on 0.4 PEFUT wire)					
km .4 PEFUT	dB at 160 kHz	0 dB	4.75 dB (0.5 km)	9.5 dB (1.0 km)	14.3 dB (1.5km)	19.0dB (2.0 km)	23.8 dB (2.5 km)
0.10	<b>0.95</b>	7616					
0.20	<b>1.9</b>	7616					
0.30	<b>2.85</b>	7616					
0.40	<b>3.8</b>	7616					
0.50	<b>4.75</b>	7616					
0.60	<b>5.7</b>	7616	7616				
0.70	<b>6.65</b>	7616	7284				
0.80	<b>7.6</b>	7616	6812				
0.90	<b>8.55</b>	7342	6435				
1.00	<b>9.5</b>	7048	6106				
1.10	<b>10.45</b>	6744	5803	5570			
1.20	<b>11.4</b>	6429	5513	4883			
1.30	<b>12.35</b>	6100	5227	4316			
1.40	<b>13.3</b>	5756	4940	3874			
1.50	<b>14.25</b>	5617	4646	3546			
1.60	<b>15.2</b>	5593	4342	3212	2944		
1.70	<b>16.15</b>	5570	4027	2888	2269		
1.80	<b>17.1</b>	5548	3698	2556	1855		
1.90	<b>18.05</b>	5526	3354	1947	1572		
2.00	<b>19</b>	5504	3215	1567	1354		
2.10	<b>19.95</b>	5482	3191	1335	1160	1213	
2.20	<b>20.9</b>	5459	3168	1129	987	940	
2.30	<b>21.85</b>	5433	3146	953	834	756	
2.40	<b>22.8</b>	5404	3124	798	694	612	
2.50	<b>23.75</b>	5370	3102	654	578	495	
2.60	<b>24.7</b>	5327	3080	536	468	383	435
2.70	<b>25.65</b>	5273	3057	420	358	303	293
2.80	<b>26.6</b>	5204	3031	320	279	176	151
2.90	<b>27.55</b>	5118	3002	228	183	110	82
3.00	<b>28.5</b>	5009	2968	227	124	49	22

3.10	<b>29.45</b>	4858	2925	227	19	0	0
3.20	<b>30.4</b>	4683	2863	226	0	0	0
3.30	<b>31.35</b>	4487	2717	218	0	0	0
3.40	<b>32.3</b>	4212	2587	217	0	0	0
3.50	<b>33.25</b>	3917	2450	216	0	0	0
3.60	<b>34.2</b>	3646	2245	215	0	0	0
3.70	<b>35.15</b>	3397	2067	213	0	0	0
3.80	<b>36.1</b>	3161	1876	152	0	0	0
3.90	<b>37.05</b>	2954	1718	143	0	0	0
4.00	<b>38</b>	2749	1553	141	0	0	0
4.10	<b>38.95</b>	2561	1397	138	0	0	0
4.20	<b>39.9</b>	2375	1250	135	0	0	0
4.30	<b>40.85</b>	2191	1098	131	0	0	0
4.40	<b>41.8</b>	2010	955	126	0	0	0
4.50	<b>42.75</b>	1852	807	110	0	0	0
4.60	<b>43.7</b>	1675	672	30	0	0	0
4.70	<b>44.65</b>	1505	541	0	0	0	0
4.80	<b>45.6</b>	1357	415	0	0	0	0

**TABLE 4-3**

**Spectral Compatibility Benchmark II values for ADSL in kbit/s as a function of range from the Highest NRP, with range from the Highest NRP to the Nominated Lower NRP as a parameter.**

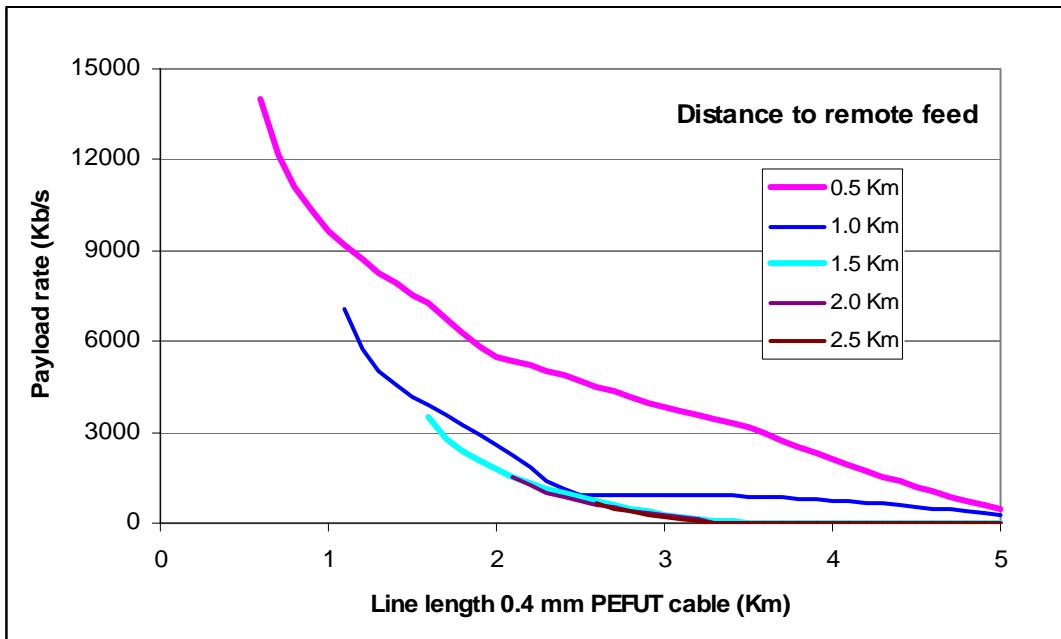

**FIGURE 4-6**

Spectral Compatibility Benchmark II values for ADSL2+ as a function of range from the Highest NRP, with range from the Highest NRP to the Nominated Lower NRP as a parameter.

Range		Attenuation at 160 kHz to remote feed (Dist on 0.4 PEFUT wire)						
km	dB at 160 kHz	0 dB	4.75 dB (0.5 km)	9.5 dB (1.0 km)	14.3 dB (1.5km)	19.0dB (2.0 km)	23.8 dB (2.5 km)	28.5 dB (3.0 km)
0.1	0.95	21117						
0.2	1.9	19281						
0.3	2.85	18191						
0.4	3.8	17408						
0.5	4.75	16794						
0.6	5.7	16286	14003					
0.7	6.65	15852	12166					
0.8	7.6	15471	11076					
0.9	8.55	15130	10293					
1.0	9.5	14820	9679					
1.1	10.45	14406	9172	7082				
1.2	11.4	13957	8722	5722				
1.3	12.35	13501	8286	5010				
1.4	13.3	13033	7901	4527				
1.5	14.25	12774	7566	4173				
1.6	15.2	12624	7257	3880	3475			
1.7	16.15	12453	6772	3536	2788			
1.8	17.1	12246	6279	3209	2371			
1.9	18.05	11979	5791	2890	2044			
2.0	19	11635	5518	2577	1763			
2.1	19.95	11200	5359	2254	1513	1546		
2.2	20.9	10672	5202	1829	1311	1237		
2.3	21.85	9931	5036	1392	1138	1021		
2.4	22.8	9305	4865	1093	978	859		
2.5	23.75	8659	4688	923	833	724		
2.6	24.7	8095	4508	921	703	606	652	
2.7	25.65	7596	4336	919	579	500	480	
2.8	26.6	7174	4166	917	471	408	365	
2.9	27.55	6785	3995	914	375	323	275	
3.0	28.5	6422	3853	912	293	245	198	
3.1	29.45	6108	3720	901	211	181	100	149
3.2	30.4	5786	3583	899	144	113	47	48
3.3	31.35	5468	3449	896	88	28	0	0
3.4	32.3	5158	3313	894	41	0	0	0
3.5	33.25	4858	3175	888	0	0	0	0
3.6	34.2	4567	2957	863	0	0	0	0
3.7	35.15	4279	2737	842	0	0	0	0
3.8	36.1	3997	2522	812	0	0	0	0
3.9	37.05	3733	2306	786	0	0	0	0
4.0	38	3483	2100	753	0	0	0	0
4.1	38.95	3263	1906	715	0	0	0	0
4.2	39.9	3032	1714	677	0	0	0	0
4.3	40.85	2817	1534	634	0	0	0	0
4.4	41.8	2604	1361	591	0	0	0	0
4.5	42.75	2412	1197	550	0	0	0	0
4.6	43.7	2226	1038	484	0	0	0	0
4.7	44.65	2062	883	460	0	0	0	0
4.8	45.6	1892	735	391	0	0	0	0
4.9	46.55	1721	598	349	0	0	0	0
5.0	47.5	1532	466	272	0	0	0	0

**TABLE 4-4**

**Spectral Compatibility Benchmark II values for ADSL2+ in kbit/s as a function of range from the Highest NRP, with range from the Highest NRP to the Nominated Lower NRP as a parameter.**

## 5 CALCULATION OF BASIS SYSTEM PERFORMANCE

For a given disturbing system type, the Basis System performance is calculated for each of the configurations in Clause 2.3.1 of Part 2 of this IMP using the cable attenuation models and parameters of Clause 5.1 of Part 2 of this IMP, the crosstalk noise environment of Clause 5.2 and the Basis System transceiver models of Clause 5.3 of Part 2 of this IMP. This calculation is implemented in a software tool which is available to Service Providers.

Basis System performance is the achievable rate versus range (or just the range for a fixed rate system) for that Basis System when the 1% worst case error rate equals  $10^{-7}$  with a 6dB margin.

### 5.1 Cable Environment

The multiplicity of cable types and gauges found in the New Zealand copper access network, and indeed in any one customer loop, cannot all be modelled separately. To simplify matters, the most common type of distribution Communications Wire, viz., 0.4mm Poly Ethylene Jelly filled Unit Twin (PEFUT) copper pair cable, is taken to be representative of the behaviour of copper access loops.

The NZ PEFUT cable has been modelled by referencing its attenuation characteristics to the cable model for 26-AWG Twisted Pair cable given in section A.3.1 and Table A.1 of ANSI T1.417-2003.

The PEFUT cable is modelled by;

$$s_{21}^{\text{PFUT, dB}}(f) = s_{21}^{\text{26AWG, dB}}(f) + L \times \left[ \Delta_0 + \alpha \times \frac{f}{1 \text{ MHz}} \right]$$

Where  $\alpha = 2.097\text{dB/Km}$  and  $\Delta_0 = 1.925\text{dB/Km}$  and  $L$  is the cable length in km.

Studies of system spectral compatibility are performed as if the whole access network were made up of 0.4mm PEFUT. The resulting deployment range limits for deployable systems are then converted, at 160Khz, to Calculated Attenuation Deployment Limits for application to mixed cable types and gauges.

The layout and make-up of the access network has a significant influence on spectral compatibility in that pairs serving customers that are widely separated geographically have a low probability of being in the same cable unit. However in some low density regions, end users served in the same cable binder could be separated by as much as 3.6km of 0.4mm cable, but in practice no more than 50 dwellings are served from the same binder and therefore the geographic span of end user cable terminals served from the same binder will be considerably less than the 3.6Km absolute maximum.

### 5.2 The Noise Environment

The types of noise considered in the analysis include:

- (a) Background white Gaussian noise at a PSD of  $-140 \text{ dBm/Hz}$  (assumed the same and added into all cases – as per T1E1.4);
- (b) Self crosstalk noise from other systems of the same type as the Disturbed System; and
- (c) Compatibility crosstalk noise from transmission systems of different type from the Disturbed System.

#### 5.2.1 Crosstalk Noise

The crosstalk noise at the input to the disturbed receiver may be via NEXT and/or FEXT paths from other pairs in the same cable.

The NEXT or FEXT path is modelled using the 1% worst case (or 99<sup>th</sup> percentile) of the power sum crosstalk noise from  $n$  disturbers. For cables with 25-pair subunits (other cables may have different unit size but still give approximately the same worst case noise for the same % of disturber fill in the unit), the worst case power sum crosstalk formulas are:

NEXT Power Sum Attenuation (NEXTPSA) is the ratio in dB of one of the  $n$  identical disturbing PSDs to the total NEXT noise from those disturbers at the NEAR end of the disturbed pair.

$$NEXTPSA = 45 - 6 \log\left(\frac{n}{4}\right) - 15 \log(f) \quad (5)$$

FEXT Power Sum Ratio (FEXTPSR) is the ratio in dB of the far end received PSD of the  $n$  identical disturbing systems to the total FEXT noise from those disturbers at the FAR end of the disturbed pair.

$$FEXTPSR = 40 - 6 \log\left(\frac{n}{4}\right) - 10 \log(f^2 l) \quad (6)$$

where  $n$  is the number of disturbers from a 25-pair subunit,  $l$  is the length of 0.4mm PEFUT cable in km, and  $f$  is in MHz.

NEXTPSA is known to remain about the same for all gauges of access network cables, due to the compensating effects of pair separation and cable attenuation. Hence it is assumed to be the same for all cables, including mixed gauge cables.

The variation of FEXT with cable gauge is less well understood, but FEXTPSR is known to increase (i.e. FEXT noise decreases for the same length) significantly with increasing gauge of the cable. However, the  $-10 \log(l)$  dependence on length results in a corresponding decrease in FEXTPSR for a heavier gauge cable run with the same attenuation. Hence FEXTPSR is assumed to be the same for all cables, including mixed gauge cables, with the same attenuation.

Category 5 cable may be used in buildings and in future broadband access networks. Its NEXTPSA and FEXTPSR are given by:

$$NEXTPSA_5 = 61.5 - 6 \log\left(\frac{n}{4}\right) - 15 \log(f) \quad (7)$$

$$FEXTPSR_5 = 55 - 6 \log\left(\frac{n}{4}\right) - 10 \log(f^2 l) \quad (8)$$

For NEXT, the NEXTPSA in dB is subtracted from the PSD in dBm/Hz transmitted by the Disturbing System to obtain the PSD of the NEXT noise at the receiver input. With PSD in dBm/Hz, the noise PSD  $N_i$  at the receiver input is:

$$N_i = PSD_i(f) - NEXTPSA(f) \quad (9)$$

For FEXT, the FEXTPSA Ratio in dB and the line attenuation in dB are both subtracted from the PSD in dBm/Hz transmitted by the disturbing system. The FEXT noise PSD  $F_i$  at the receiver input is:

$$F_i = PSD_i(f) - FEXTPSR(f) - A(f) \quad (10)$$

where A(f) is the line attenuation in dB.

### 5.2.2 Transmit Power Spectral Densities of Disturbing Systems

The transmit Power Spectral Density (PSD) of the Disturbing Systems are modelled as templates which have been obtained from the relevant standards and system descriptions as follows. The key requirement is that, for a standard which has a line code and PSD mask defined, the template provides a close approximation to the real transmit PSDs of systems which meet the standard. Hence the following approach:

- (a) The midband PSD in the template is taken to be the nominal value specified in the relevant standard; and
- (b) The remainder of the template, in the regions of high and low frequency rolloff, should be less than or equal to the mask in the standard, and attempt to more closely follow the actual ideal PSD dictated by the line code. Several such templates have been drawn from the ANSI T1.417-2003 and ITU-T Recommendations G.992.3 and G.992.5. Others such as those for SHDSL (ITU G.991.2) are drawn directly from the relevant standard.

For systems which are in common use but are not standards or draft standards, templates have been based on ideal transmit PSDs (E1) or on obvious extensions from similar standard systems.

Note that all noise models must include an additional -140 dBm/Hz of white Gaussian noise.

These templates are exactly the same as the PSDs which are given for the exchange end in the Appendices to Part 3 of this IMP and for the customer end in the relevant standards outlined in Appendix A of this Part. The table also gives the relevant frequency at which any range restrictions for each technology are to be converted to attenuation in dB for application to cable types other than the 0.4mm PEFUT cable analysed.

### 5.2.3 Noise Power Summation Method

The FSAN model is adopted in this IMP for the summation of crosstalk noise. T1.E1.4/98-189 provides a detailed description and justification of that model.

The model states that when summing multiple NEXT disturbers (or multiple FEXT, but not NEXT and FEXT together), the NEXT noise powers  $N_i$  in dB must be added as follows to give the total noise power N.

$$N = 6 \log_{10} \left[ \sum_i 10^{N_i/6} \right] \quad (11)$$

When adding NEXT to FEXT and other noise, the noises are added directly in mW/Hz, where N and F are in dB, viz.

$$TotalNoise(dB) = 10 \log_{10} \left[ 10^{N/10} + 10^{F/10} \right] \quad (12)$$

## 5.3 Transceiver Models for Basis Systems

A transceiver model has been developed for each Basis System. For each Basis System transceiver model it is important to ensure insofar as possible that the computed transmission performances are representative of those achievable with real equipment operating in the real network.

The underlying aim is to develop models that are representative of the majority of equipment likely to be deployed for each potential basis xDSL type. Consequently each model has been first developed in an ideal form, and then adjusted to account for the non-idealization effects of real equipment. The adjustments have been made either against the transmission performance specifications of an appropriate international Standard or draft Standard, or against the known measured performances of relevant commercially available equipment. The adjustment in dB which must be applied to the ideal receiver performance is quoted for each of the Basis Systems in Clauses 5.3.1 to 5.3.4 of Part 2 of this IMP.

It is important to note here, that for each technology the degree of adjustment has been chosen so as to align the model performances with those achievable with well engineered equipment, but not with the highest attainable by unrepresentative very high state-of-the-art systems.

The process just referred to for aligning model performances with those of actual equipment inherently incorporates with it one means of assessing the veracity of the models in question. In addition, the majority of assessments reported here have been obtained using two independently developed computer programs for each basis transceiver. Thus the estimates of each program have been verified against those of the other.

Trellis coding is used in several types of DSL transceivers, and a coding gain in dB is applied to account for the advantage thereby obtained. Generally, the trellis coder adds additional redundant bits to the data symbols, and then uses the redundant information to make more accurate decisions in a noisy environment.

A Decision Feedback Equaliser (DFE) is used in several DSL receivers to optimize the SNR at the decision point of the receiver. Because the performance is dependent on the number of taps and other design features of the digital signal processing used, it has been decided to use ideal (infinite tap count) DFEs for these studies, and then to degrade all DFE-based receivers by an amount to account for practical realisation.

#### 5.3.1 ADSL Transceiver Model

The ADSL DMT transceiver is based on an ideal model similar to that due to Cioffi (Ref. 1) with parameters according with ITU-T Recommendation G.992.1. Specifically:

- (a) Bit allocation is based on transmit PSD of -38dBm/Hz up and -40 dBm/Hz down for all allocated subchannels (or -3.65 dB per 4.3125 kHz sub-channel) together with up to +/- 1.5 dB power adjustment to achieve equal signal to noise ratio in all subchannels;
- (b) Sub-channels used are determined from the standard PSD masks. The downstream mask for FDD operation employs the reduced NEXT option (i.e. non-overlapped spectra). The subchannels used for upstream are 6 to 31 and for downstream 38 to 256 with subchannel 64 reserved for the pilot tone.
- (c) Maximum bits per sub-channel = 14 (up and down);
- (d) Minimum bits per sub-channel = 2 (up and down);
- (e) Assumed coding gain of combined Reed-Solomon FEC and Trellis coding = 3 dB;
- (f) Overhead rate (with fast and slow buffers) = 192 kbit/s down, and 128 kbit/s up;
- (g) Power cutback (refer to Table C-2 in Part 3 of this IMP) and
- (h) No additional overhead FEC.

To just meet the requirements of G.992.1 Region A test loops and test noise conditions, the receiver model used for this Basis System is assumed to be the ideal model.

#### 5.3.2 ADSL2+ Transceiver Model

The ADSL2+ DMT transceiver is based on an ideal model similar to that due to Cioffi (Ref. 1) though with parameters according with ITU-T Recommendation G.992.5. Specifically:

- (a) Bit allocation is based on the non-overlapped downstream and upstream transmit PSD templates defined in Table A.3 and A.5 of G.992.5 respectively.
- (b) Sub-channels used are determined from the Standard PSD masks. The downstream mask for FDD operation employs the reduced NEXT option (i.e. non-overlapped spectra). The subchannels used for upstream are 6 to 31 and for downstream 38 to 511 with subchannel 64 reserved for the pilot tone;
- (c) Max bits per sub-channel = 15 (up and down);
- (d) Minimum bits per sub-channel = 1 (up and down);
- (e) Assumed coding gain of combined Reed-Solomon FEC and Trellis coding = 4.2 dB;
- (f) Overhead rate (with fast and slow buffers) = 192 kbit/s down, and 128 kbit/s up;
- (g) Power cutback (refer to Table C-2 in Part 3 of this IMP) and
- (h) No additional overhead for trellis coding or FEC.

#### 5.3.3 ISDN-BR Transceiver Models

The 2B1Q transceiver model employs an ideal DFE-based representation that is adjusted to account for the limitations of representative actual systems. The ideal DFE-based representation is that set out in the draft ANSI Spectrum Management Standard (Ref. 2). The representation has been developed from the optimal mean-square error formulation due to Salz (Ref. 3). The transmit PSD is assumed to be ideal –

- 2B1Q line coded full width rectangular pulses, filtered by a 2<sup>nd</sup> order Butterworth filter at the baud rate.
- The total transmitted power integrated over the frequency range from 0 to the baud rate shall be exactly +14 dBm

To just meet the requirements of G.961 or G.991.1 test loops, the receiver model for this Basis System is assumed to have 5 dB worse performance than the ideal receiver.

#### 5.3.4 E1-HDB3 Transceiver Model

The E1-HDB3 receiver is modelled as an ideal linear equaliser with the following characteristics (some from G.703):

- (a) Assumed 100% raised cosine (frequency domain) pulse shape at receiver eye;
- (b) Half-width rectangular transmit pulse shape, with peak amplitude = 3.0V; and
- (c) Baud rate = 2048 kbaud.

The difference between this ideal equaliser and well designed practical receivers is 1-2 dB. Hence the receiver model for this Basis System is assumed to have 2 dB worse performance than the ideal receiver.

Tests for interference into the E1 Basis System must include 10 E1 NEXT disturbers in the opposite direction of transmission which are not in the same cable unit as the Basis System (these are conservatively assumed to cause 10 dB less NEXT than for disturbers within the same cable unit), 10 E1 FEXT disturbers in the same direction of transmission which are in the same cable unit, 10 disturbers of the Deployment Class under test. The requirement for the protection of legacy E1 Basis Systems is for a BER of  $10^{-7}$  with a margin of 6 dB at a range of 1 km. If this test fails with the systems under test in the same cable unit, then pair separation at the lowest NRP of that Deployment Class is required.

### 5.3.5 Voiceband

This IMP does not directly specify a benchmark performance for voiceband systems but instead controls the interference into voiceband systems by limiting the transmit PSD of all disturbing systems within the voiceband.

The total power of any disturbing system in the frequency band  $0 < f < 4$  kHz shall be less than  $-9\text{dBm}$  ( $600\Omega$ ) for signals transmitted continuously for more than 5 secs.

### 5.3.6 SHDSL and ESHDSL Transceiver Model

The SHDSL transceiver model employs an ideal DFE-based representation that is adjusted to account for the limitations of representative actual systems.

The necessary target SNR in order to achieve a given Margin is equal to:

$$SNR_{dB} = SNR_{req} - \text{Coding Gain} + \text{Implementation Loss} - \text{Margin}$$

where:

- $SNR_{req}$  is 27.71 dB for IMPd 16-PAM systems and 33.80 dB for IMPd 32-PAM systems.
- Coding gain is 5dB
- Implementation Loss is 2dB
- Margin is 6dB

The Signal to Noise ratio is given by the discrete form of the DFE-based SNR formula,  $SNR_{dB}$ , given below:

$$SNR_{dB} = \frac{1}{M} \sum_{k=1}^M 10 \log_{10} \left( 1 + \frac{S(f_{sym} - f_k) |H(f_{sym} - f_k)|^2}{N(f_{sym} - f_k)} + \frac{S(f_k) |H(f_k)|^2}{N(f_k)} + \frac{S(2f_{sym} - f_k) |H(2f_{sym} - f_k)|^2}{N(2f_{sym} - f_k)} + \frac{S(f_{sym} + f_k) |H(f_{sym} + f_k)|^2}{N(f_{sym} + f_k)} \right)$$

where:

$S(f)$  shall be the nominal far-end transmit signal power spectral density,

$|H(f)|^2$  shall be the magnitude squared of the ideal loop insertion gain function described in section 5.1,

$N(f)$  shall be the injected crosstalk noise power spectral density as described in section 5.2.

$f_{sym}$  shall be the transmit symbol rate and is equal to (payload rate + overhead) / (number of bits per symbol). A IMPd 16-PAM system has 3 bits per symbol while a IMPd 32-PAM system has 4 bits per symbol. Overhead is 8 kbit/s.

For this application use  $f_k = k$  kilohertz,  $k = 1 \dots M$ , where  $M$  is the maximum value of  $k$  such that  $M < f_{sym} \leq (M+1)$ .

The equation for the nominal PSD  $S(f)$  is defined in G.991.2.

## 6 EXPECTED WORST CASE WIDEBAND NOISE MASK BELOW 2.208MHz ON THE MPF

- 6.1 This section describes the development and definition of an indicative Wideband noise test for an MPF. The specification accounts for crosstalk noise from disturbing systems belonging to Deployment Classes and deployed according to Deployment Rules. However, it should be noted that it excludes all other possible noise components, such as impulsive noise, and RFI from AM broadcast stations, which are likely to be encountered on actual lines. The expected worst case noise PSD has been calculated for all possible Disturbing Systems when deployed from an MPF-NRP at a single location. This model applies to both Deployment States A and B as described in Part 1 of this IMP. The process for determination of this worst case noise is as follows:
- (1) Determine the 1% worst case crosstalk noise PSD at each end of the cable for 21 disturbers of the given Deployment Class at each end within a 25-pair cable unit;
  - (2) Repeat for all Deployment Classes at a given line length;
  - (3) Find the maximum of the 1% worst case crosstalk noise PSD over all classes at the given length;
  - (4) Repeat at several lengths up to 5 km of 0.4mm PEFUT cable, to obtain a length dependent set of noise PSDs at the customer end; and
  - (5) Convert the range parameter on the curves to dB at 160 kHz to allow reference to cable types other than 0.4mm PEFUT.
- 6.2 The worst case noise mask of power in 3 kHz at the Deployment Reference Point for an asymmetric Deployment Class is described in Figure 6-1 and Table 6-1 of Part 2 of this IMP. The worst case noise PSD masks at the MPF-EURP in Figure 6-2 and Table 6-2 of Part 2 of this IMP are plotted with the attenuation at 160 kHz as a parameter.
- 6.3 In Deployment State A, the worst case noise mask applies with the attenuation parameter based on the range from the Highest NRP.
- 6.4 In Deployment State B;
- (1) the network end noise mask in Figure 6-1 applies to all NRPs between the Highest NRP and the Nominated Lower NRP.
  - (2) the customer end noise mask in Figure 6-2 applies where the attenuation parameter is measured from the Nominated Lower NRP. Note that this corresponds to more severe customer end noise for systems fed from the exchange in Deployment State B, compared with Deployment State A.
- 6.5 The worst case wideband noise masks represent the 1% worst case noise PSD due to crosstalk from all Deployment Class Systems on the reference 0.4mm PEFUT cable. These masks are expected to be exceeded in less than 1% of cases on unit cables, but may be exceeded in a larger percentage of cases on quad cable.
- 6.6 The effect of radio frequency interference on MPF noise is to introduce large spikes associated with AM radio broadcasts; these spikes are tolerated by most DSL systems and they should not be considered exceedances.
- 6.7 Exceedance of the mask does not necessarily result in system failure because the frequency bands used by the systems may not align with the frequencies at which exceedance occurs. System failures may occur even when the mask is not exceeded because of wideband interference due to combinations of multiple

crosstalk and external noise sources. Therefore the mask is only indicative of a more severe noise environment.

## 7 REFERENCES

1. Cioffi, J. "A MultiCarrier Primer". ANSI Standards Committee T1 Submission, T1E1.4/91-157, 11<sup>th</sup> November 1991.
2. ANSI T1.417-2003.Spectrum Management for Loop Transmission Systems. Sept. 2003.
3. Salz, J. "Optimum Mean-Square Decision Feedback Equalization". BSTJ, October 1973, pp1341-1373.
4. FSAN VDSL working group " A new analytical method for NEXT and FEXT noise calculation", T1.E1.4 contribution 98-189, 28 May 1998.
5. ITU-T Recommendation G.991.2 " SHDSL"
6. ETSI TR 101 830-1 v1.4.1 (2006-03) Access networks, Spectral management on metallic access networks, Part 1 : Definitions and signal library
7. ITU-T Recommendation G993.2 "VDSL2"
8. ITU-T Recommendation G993.2 Amd. 1

## APPENDIX A

### TRANSMIT PSD TEMPLATES FOR DEPLOYMENT CLASS SYSTEMS

This Appendix gives the transmit PSD templates for the Deployment Class Systems which are used to define the disturbing systems in the calculation of Basis System performance. These templates correspond to the Nominal requirements for the Deployment Classes referenced in Part 3 of this IMP.

Note that the Reference Frequency is always derived from the upper rate of the deployment class, and may not match exactly with a column in Table A-2 of Part 1 of this IMP.

Deployment Class	Reference to source of Transmit PSD Template	Midband PSD or other parameter	Typical Technology (informative)	Reference frequency for class (kHz) (Note 2)
1b	Table B-2 of Part 3 of this IMP Ideal based on G.703. (Only for assessment of interference into E1 Basis System. Not to be used as an interferer into other Basis Systems)	$V_{\text{peak}} = 3.1\text{V}$	E1 HDB3	1024
2a	Reserved			
3a	Reserved			
4a	AS/ACIF S043.2 Appendix A	-32 dBm/Hz	ISDN BR 2B1Q	40
5a	Reserved			
5b	Reserved			
6a	G992.1 section A.1.3 downstream and A.2.4 upstream	Up -38 dBm/Hz Down -40 dBm/Hz	ADSL reduced NEXT	160
6b	Reserved			
6c	Reserved			
6d	Reserved			
6e	G992.1 section A.1.3 downstream with pass band reduced by 10dB and A.2.4 upstream	Up -38 dBm/Hz Down -50 dBm/Hz	ADSL FD Low Power	160
6f	Reserved			
6g	G.992.3 Annex L; section L.1.3 for downstream and L.2.3	Up -32.9 dBm/Hz Down -37 dBm/Hz	Re-ADSL2 (upstream mask 2)	160

Deployment Class	Reference to source of Transmit PSD Template	Midband PSD or other parameter	Typical Technology (informative)	Reference frequency for class (kHz) (Note 2)
	downstream			
6h	G.992.3 and G.992.5 section A.1.3 for downstream, and section A.2. upstream	Up -38 dBm/Hz Down -40 dBm/Hz	ADSL2 and ADSL2+ (non-overlapped mode)	160
6i	G.992.5 Annex I, section 1.2.1 upstream and section I.1.3 downstream	Up -38 dBm/Hz Down -40 dBm/Hz	ADSL2+ All Digital (non-overlapped mode)	160
6j	G.992.3 and G.992.5 Annex M	Up -39 dBm/Hz Down -40 dBm/Hz	ADSL2 and ADSL2+ non overlapped spectrum with extended upstream bandwidth (Annex M) Mask EU-40	160
6k	G.992.3 and G.992.5 Annex M	Up -40.1 dBm/Hz Down -40 dBm/Hz	ADSL2 and ADSL2+ non overlapped spectrum with extended upstream bandwidth (Annex M) Mask EU-52	160
6l	G.992.3 and G.992.5 Annex M	Up -40.4 dBm/Hz Down -40 dBm/Hz	ADSL2 and ADSL2+ non overlapped spectrum with extended upstream bandwidth (Annex M) Mask EU-56	160
6m	G.992.3 and G.992.5 Annex M	Up -40.7 dBm/Hz Down -40 dBm/Hz	ADSL2 and ADSL2+ non overlapped spectrum with extended upstream bandwidth (Annex M) Mask EU-60	160
6n	G.992.3 and G.992.5 Annex M	Up -41 dBm/Hz Down -40 dBm/Hz	ADSL2 and ADSL2+ non overlapped spectrum with extended upstream bandwidth (Annex M) Mask EU-64	160
7	Reserved			
8a	Reserved			

Deployment Class	Reference to source of Transmit PSD Template	Midband PSD or other parameter	Typical Technology (informative)	Reference frequency for class (kHz) (Note 2)
8b	Frequency scaled ANSI SM Class 3 template.	-39 dBm/Hz	HDSL 2B1Q 1168 kbit/s	160
8c	Reserved			
9a	G.991.2 Template	Based on Formula in equation (13)	SHDSL (up to 576 kbit/s)	160
9b	G.991.2 Template	Based on Formula in equation (13) reduced by 3.5 dB	SHDSL (up to 776 kbit/s, reduced power)	160
9c	G.991.2 Template	Based on Formula in equation (13)	SHDSL (up to 776 kbit/s)	160
9d	G.991.2 Template	Based on Formula in equation (13)	SHDSL (up to 1160 kbit/s)	160
9e	G.991.2 Template	Based on Formula in equation (13)	SHDSL (up to 1544 kbit/s)	160
9f	G.991.2 Template	Based on Formula in equation (13)	SHDSL (up to 2056 kbit/s)	160
9g	G.991.2 Template	Based on Formula in equation (13)	SHDSL (up to 2312 kbit/s)	160
9h	G991.2 Template	Based on Formula in equation (13)	SHDSL (up to 1800 kbit/s)	160
9i	G991.2 Annex F	Based on Formula in equation (13)	ESHDSL (up to 2624 kbit/s)	160
9j	G991.2 Annex F	Based on Formula in equation (13)	ESHDSL (up to 2880 kbit/s)	160
9k	G991.2 Annex F	Based on Formula in equation (13)	ESHDSL (up to 3072 kbit/s)	160
9l	G991.2 Annex F	Based on Formula in equation (13)	ESHDSL (up to 3264 kbit/s)	160
9m	G991.2 Annex F	Based on Formula in equation (13)	ESHDSL (up to 3456 kbit/s)	160
9n	G991.2 Annex F	Based on Formula in equation (13)	ESHDSL (up to 3648 kbit/s)	160

Deployment Class	Reference to source of Transmit PSD Template	Midband PSD or other parameter	Typical Technology (informative)	Reference frequency for class (kHz) (Note 2)
9o	G991.2 Annex F	Based on Formula in equation (13)	ESHDSL (up to 3840 kbit/s)	160
9p	G991.2 Annex F	Based on Formula in equation (13)	ESHDSL (up to 5376 kbit/s) (Note 1)	160
9q	G991.2 Annex F	Based on Formula in equation (13)	ESHDSL (up to 5696 kbit/s) (Note 1)	160
10	G993.2 Annex B Table B-4 and Table B-5	<p><b>Below 2.208MHz</b> As per Class 6</p> <p><b>Above 2.208MHz</b> Downstream :the nominal PSD mask for each band as defined in Appendix P1 of Part 3 of this IMP</p> <p>Upstream: the nominal PSD mask for each band as defined in Appendix P2 of Part 3 of this IMP</p>	VDSL2	160

**TABLE A-1**

**List of PSD Templates for Deployment Classes: for use in determining Unacceptable Interference into a Basis System**

*NOTE 1: only 4 bits/symbol available at this data rate in the ESHDSL Recommendation.*

*NOTE 2: Reference Frequency here may not align exactly with the column in Table A-2 in Part 1 of this IMP..*

Midband PSDs and templates for the SHDSL and ESHDSL systems with variable rate in Table A-1 of Part 2 of this IMP above are based on formulae which scale the PSD while retaining the same total transmit power for all rates.

For SHDSL and ESHDSL the transmit PSD template is defined in G.991.2. The midband PSD and the baud rate are related by equation 13:

$$Midband\_PSD(dBm/Hz) = 10 \log_{10} \left( \frac{K}{135B} \right) \quad (13)$$

where the baud rate B (kbaud) is equal to the bit rate (kbit/s) divided by the number of bits per symbol (3 using 16-TCPAM encoding, 4 using 32-TCPAM encoding), and the constant K is given by:

if  $B < 2056/3$ ,  $K=7.86$ ,

if  $B \geq 2056/3$ ,  $K=9.9$ . (14)