

NEW ZEALAND

COPPER LOCAL LOOP

PRELIMINARY

INTERFERENCE MANAGEMENT PLAN

PART 1

MPF PERFORMANCE REQUIREMENTS

NOVEMBER 2007

CONTENTS

CONTENTS	3
1 SCOPE	1
2 OBJECTIVES	2
2.1 General Overview	2
2.2 Specific Objectives	2
3 (UNUSED)	3
4 REFERENCES AND RELEVANT DOCUMENTS	4
5 DEFINITIONS AND ABBREVIATIONS	6
5.1 General	6
5.2 Abbreviations	6
5.3 Definitions	7
6 (UNUSED)	13
7 REFERENCE ARCHITECTURE FOR SERVICES USING THE MPF	14
7.1 Background	14
7.2 MPF Reference Architecture	14
7.3 Single and Multiple Feed Distribution Areas	15
7.4 Performance Implications of Single and Multiple Feed DAs	16
7.5 Deployment States A and B	16
7.6 Deployment Reference Points	17
7.7 Lowest Asymmetric System Feed Point	18
8 PERFORMANCE REQUIREMENTS FOR OPERATION OF SYSTEMS USING THE MPF	19
8.1 General	19
8.2 Rules for Operation of Systems using the MPF	20
8.3 Operation of Deployment Class Systems	21
8.4 Operation of Non-Deployment Class Systems	21
8.5 Use of More Than One System Type on a single MPF	23
8.6 Trials and Extraordinary or Temporary uses	24
9 POWER FEEDING OF REMOTE EQUIPMENT USING THE MPF	25
9.1 Overview	25
9.2 General Requirements of Power Feeding Equipment connected to MPF	25
9.3 Safety Requirements for Power Feeding into End User Premises	25
10 COMPLIANCE WITH PERFORMANCE REQUIREMENTS UNDER THIS IMP26	
10.1 Overview	26
10.2 Responsibility for Compliance	26
10.3 Compliance with Deployment Class Requirements	26
10.4 Standards Compliance	26
10.5 Laboratory Compliance	26
10.6 Operational Compliance	26

11	OPERATION OF SYSTEMS IN END USER PREMISES (INFORMATIVE)	27
12	(UNUSED)	28
13	(UNUSED)	29
14	STATUTORY COMPLIANCE	30
	APPENDIX A METHOD FOR DETERMINATION OF DEPLOYMENT LIMIT COMPLIANCE.	31
	APPENDIX B MEASUREMENT METHODOLOGY	33

1 SCOPE

- 1.1 This Interference Management Plan (**IMP**) applies to Telecom and to other Service Providers that use Telecom's local loop network as defined in Schedule 1 of the Telecommunications Act 2001 (i.e. "that part of Telecom's copper network that connects the end user's building (or, where relevant, the building distribution frames) to the handover point in Telecom's local telephone exchange or distribution cabinet (or equivalent facility)").
- 1.2 This IMP uses the term 'MPF' to mean a pair of twisted copper conductors between the relevant demarcation point at the End User's premises and the relevant demarcation point at a Telecom local exchange or Active Cabinet that conveys signals when connected to an electronic communications network. This use of 'MPF' is different to the use of MPF in the rest of the UCLL Standard Terms. Elsewhere in the UCLL Standard Terms, MPF includes only twisted copper conductors between the exchange and an End User's premises
- 1.3 In relation to managing interference between voice frequency services Telecom's specification of PTC 200 "Requirements for Connection of Customer Equipment to Analogue Lines" (as annexed) will apply.
- 1.4 This IMP does not apply to:
- (a) systems operated on conditioned Communications Wire;
 - (b) systems deployed and in operation on Communications Wire prior to this IMP coming into effect;
 - (c) Copper Backhaul Cables.
- 1.5 This IMP does not apply to the conditioning of unconditioned local loops (including Telecom's unconditioned local loops).
- 1.6 Clause 8.2.1 of Part 1 of this IMP does not apply to a Trial System or Extraordinary and Temporary Use System.

Note: Clause 8.6 of Part 1 of this IMP defines when a system is a Trial or Temporary and Extraordinary Use system for the purposes of Clause 1.6 of Part 1 of this IMP.

2 OBJECTIVES

2.1 General Overview

- 2.1.1 Broadband telecommunications systems and other systems in the same cable unit could interfere with each other unless performance requirements are in place to limit such interference. The purpose of this IMP is to keep the probability of undue interference into other well-designed systems within acceptable limits by controlling the deployment of each type of system which could be used on MPFs.
- 2.1.2 This IMP establishes performance requirements which systems must meet and only systems which meet the requirements of this IMP may be operated on MPFs. The UCLL Standard Terms provide that the Access Seeker and Telecom must comply with this IMP.
- 2.1.3 This IMP is consistent with the interference management methodology set out in the Communications Alliance code ACIF C559:2006 Unconditioned Local Loop Service (ULLS) Network Deployment Rules Industry Code except that it has been adapted where necessary and justified for the New Zealand environment.

2.2 Specific Objectives

- 2.2.1 The objectives of this IMP are:
- (a) To protect the integrity of Telecom's Network when systems and services (including POTS) are operated using the MPF;
 - (b) To facilitate the most efficient use of the MPF for the deployment of telecommunications services taking into account the nature of access networks and the likely use of the MPF;
 - (c) To limit to an acceptable level the risk of interference between systems and services (including POTS) operated using the MPF;
 - (d) To identify specific Deployment Classes with associated Deployment Rules which, if complied with, will ensure a Service Provider will meet the obligations in this IMP;
 - (e) To prescribe the process by which new Deployment Classes may be identified and new services operated using the MPF;
 - (f) To develop performance requirements for the operation of systems using the MPF that promote the long term interests of end users and the efficiency of the New Zealand communications industry;
 - (g) To facilitate the supply of diverse and innovative telecommunications services using the MPF;
 - (h) To specify the safety requirements for equipment that uses remote power feeding and is used as part of the operation of a system using the MPF; and
 - (i) To avoid the use of spectrum prior to the consideration by the telecommunications industry of the most efficient use of that spectrum in the operation of systems using the MPF.
- 2.2.2 This IMP is intended to be consistent with the standard access principles under clause 5 of Schedule 1 to the Act (subject to the limits on the application of those principles under the Act).

3 (UNUSED)

4 REFERENCES AND RELEVANT DOCUMENTS

Publication	Title
New Zealand Standards	
AS/NZS 60950.1:2003	Information Technology Equipment - Safety - General Requirements
PTC Specifications	
PTC 200	Requirements for Connection of End User Equipment to Analogue Lines September 2006
PTC 220	Requirements for Private Voice Networks connected to PSTN/ISDN (draft February 2003)
PTC 222:1999	Telecom Requirements for End User Premises Cable (2 or 4 pairs, with 0.5 mm conductors)
PTC 225:2003	Draft Requirements for Star Wiring Boxes and Small Office/Home Office (SOHO) Cabling Installations)
PTC 273	Requirements for ADSL2+ CPE
PTC 280	Interim Telecom Requirements for End User Connected ADSL Line Filters
ANSI/ATIS Committee T1 Publications	
ANSI T1.413-1998	Network and Customer Installation Interfaces - Asymmetric Digital Subscriber Line (ADSL) Metallic Interface
ANSI T1.417-2003	Spectrum Management for Loop Transmission Systems. Sept. 2003
ANSI T1-418-2000	High bit rate Digital Subscriber Line
ATIS Committee T1 TR 59	Single-Carrier Rate Adaptive Digital Subscriber Line (RADSL)
International Telecommunications Union	
G.703 (11/01)	Physical/electrical characteristics of hierarchical digital interfaces
G.961 (03/93)	Digital transmission system on metallic local lines for ISDN basic rate access
G.991.1 (10/98)	High bit rate Digital Subscriber Line (HDSL) Transceivers
G.991.2 (12/03)	Single-Pair High-Speed Digital Subscriber Line (SHDSL) Transceivers
G.992.1 (07/99)	Asymmetrical Digital Subscriber Line (ADSL) Transceivers
G.992.2 (07/99)	Splitterless Asymmetric Digital Subscriber Line (ADSL) Transceivers

G.992.3 (01/05)	Asymmetric Digital Subscriber Line transceivers 2 (ADSL2)
G.992.4 (07/02)	Splitterless asymmetric Digital Subscriber Line transceivers 2 (splitterless ADSL2)
G.992.5 (01/05)	Asymmetrical Digital Subscriber Line (ADSL) transceivers - Extended bandwidth ADSL2 (ADSL2+)
G.993.1 (06/04)	Very high speed digital subscriber line transceivers
G.996.1 (02/01)	Test Procedures for Digital Subscriber Line (ADSL) Transceivers
K.50 (02/00)	Safe limits of operating voltages and currents for telecommunication systems powered over the network
O.41 (10/94)	Psophometer for use on telephone-type circuits
O.151 (10/92)	Error performance measuring equipment operating at the primary rate and above
O.152 (10/92)	Error performance measuring equipment for bit rates of 64 kbit/s and N x 64 kbit/s
O.153 (10/92)	Basic parameters for the measurement of error performance at bit rates below the primary rate

5 DEFINITIONS AND ABBREVIATIONS

5.1 General

References to clauses or sections are references to clauses or sections in this IMP unless expressly provided otherwise. This section sets out definitions and abbreviations for terms contained in this IMP that are not defined in the UCLL General Terms or are defined differently to how they are defined in the General Terms. Otherwise, the definitions set out in the UCLL General Terms apply.

5.2 Abbreviations

For the purposes of this IMP, the following abbreviations apply:

2B1Q	Two Binary One Quaternary (line code)
ADSL	Asymmetric Digital Subscriber Line
ADSL2	Asymmetric Digital Subscriber Line version 2
ADSL2+	Extended bandwidth ADSL2
CAM	Customer Access Module
CCF	Cross Connect Frame
DA	Distribution Area
DFE	Decision Feedback Equaliser
DMT	Discrete Multi Tone
DP	Distribution Point
DRP	Deployment Reference Point
DSL	Digital Subscriber Line
EC	Echo Cancelling
ECP	Equipment Connection Point
EPL	Estimated Power Loss
ESA	Exchange Serving Area
ESHDSL	Single-Pair High-Speed Digital Subscriber Line Extended rate
ETP	External Termination Point
FD	Frequency Division
FDD	Frequency Division Duplex
FEC	Forward Error Correction
FEXT	Far End Cross Talk
FEXTPSR	FEXT Power Sum Ratio
FSAN	Full Services Access Network
HCLL	High Capacity Local Loop
HDB3	High Density Bipolar of order 3 (line code)
HDSL	High bitrate Digital Subscriber Line
HDP	Handover Distribution Point
ISDN	Integrated Services Digital Network

MDF	Main Distribution Frame
MPF	Metallic Path Facility
NEXT	Near End Cross Talk
NEXTPSA	NEXT Power Sum Attenuation
NRP	Network Reference Point
NTD	Network Termination Device
PEFUT	Polyethylene insulated, petroleum grease filled, unit twin cable
POI	Point of Interconnection
POI-MPF	Point Of Interconnection to the MPF
POTS	Plain Old Telephone Service
PSD	Power Spectral Density
PSTN	Public Switched Telephone Network
ReADSL	Reach extended ADSL2
SDSL	Symmetric Digital Subscriber Line
SHDSL	Single-pair High-speed Digital Subscriber Line
SNR	Signal to Noise Ratio
TCPAM	Trellis Coded Pulse Amplitude Modulation
MPF-EURP	MPF End User Reference Point
MPF-NRP	MPF Network Reference Point
UBA	Unbundled Bitstream Access
VDSL	Very high speed Digital Subscriber Line

5.3 Definitions

For the purposes of this IMP, the following definitions apply:

Access Seeker

means a Service Provider other than Telecom.

Active Cabinet

means a roadside cabinet in which broadband network equipment is housed.

Basis System

means a telecommunications system that has a determined Spectral Compatibility Benchmark.

NOTE: Some, but not all, Legacy Systems are Basis Systems. Basis Systems provide the basis for ensuring network integrity.

Bridged Tap

means a length of unterminated Communications Wire connected in parallel across a Communications Wire.

Broadband

means frequencies above 20 kHz.

Cable Unit

is a group of twisted pairs that are wrapped together within a main, branch or distribution cable. For the purposes of this IMP, this group of twisted pairs is 25 pairs unless otherwise stated

Calculated Attenuation

is the calculated sum of the attenuations in dB of all inline cable segments, excluding Bridged Taps, of the Communications Wires between specified end points at any given frequency.

Commission

means the Commerce Commission in the course of performing its functions under the Act.

Communications Wire

is a copper based wire, forming part of a public telecommunications network.

Compliant System

means a system that complies with this IMP.

Copper Backhaul Cable

means a copper cable used solely for backhaul services between local exchanges or between a local exchange and an Active Cabinet.

Cross Connect Frame

is a termination device for multiple cables consisting of wire terminating modules or strips, allowing Communications Wires from one or more cables to be connected to Communications Wires in another cable but does not include cable joints where the connections are considered to be permanent and not accessible.

NOTE: A CCF logically has a D (Distribution) and E (Exchange) side, but does not have to be actually implemented as two discrete sides as in a traditional distribution frame. The major types of CCF within the local loop are located within traditional exchange buildings (MDFs), within roadside cabinets and specific street furniture (pillars). There may also be CCFs within End User premises.

Deployment Classes

are classes of systems that comply with the performance requirements specified under this IMP when the systems are operated in accordance with the Deployment Rules associated with the particular Deployment Class. The Deployment Classes are contained in Part 3 of this IMP.

NOTE: Clause 8.4 of Part 1 of this IMP sets out the requirements for operation of systems that do not fall within a Deployment Class ('non-Deployment Class systems') contained in Part 3 of this IMP.

Deployment Class System

means a system that corresponds to a Deployment Class contained in Part 3 of this IMP.

Deployment Limit

is the maximum permitted Calculated Attenuation, at the reference frequency for the Deployment Class, from the Deployment Reference Point to the End User end of the MPF Loop Trace.

Deployment Reference Point

is the point identified in accordance with Clause 7.6 of Part 1 of this IMP.

Deployment Rule

is a constraint or prohibition or permission under this IMP applying to the operation of systems belonging to a Deployment Class.

Deployment State A

is a particular categorisation of a DA in accordance with Clause 7.5 of Part 1 of this IMP.

Deployment State B

is a particular categorisation of a DA in accordance with Clause 7.5 of Part 1 of this IMP.

Distribution Area

is a designated sub-division of an Exchange Serving Area directly served by a single Lower CCF, or in the case of direct connection to the Upper CCF, the area directly served from the Upper CCF.

<i>NOTE: "Directly served" means that there is no other CCF between that Lower CCF and the ETP.</i>

Distribution Point

means the point where the lead in cable is connected to the distribution cable.

Disturbed System

is the system that is subject to crosstalk interference from a disturbing system.

Disturbing System

is the system that acts as the cause of crosstalk interference into a disturbed system.

Downstream

means the direction from the NRP to the ETP.

Equipment Connection Point

is the point where End User equipment connects to End User cabling which is connected to the MPF at the ETP.

<i>NOTE: End User equipment may include multiple items (e.g. one or more telephone handsets associated with a End User's ADSL modem).</i>

Exchange Serving Area

is the area served from a traditional local exchange building.

External Termination Point

Is the External Termination Point for telecommunications services at an End User's premises or, where there is no termination point external to the premises, either the first jack on the premises wiring or, alternatively, the building distribution frame.

Handover Distribution Point

is the point where an Access Seeker gains access to the MPF in an exchange or an Active Cabinet.

Highest CCF

is the CCF that is furthest from the ETP.

Highest NRP

is the location of the NRP at the Highest CCF that serves the DA.

Legacy Systems

are systems of a type which were present in the network before publication of this document.

Low band

in this IMP means frequencies up to 20 kHz.

Lower CCF

is a CCF closer to the ETP than the Upper CCF, where there is continuity of Communications Wire between both CCFs.

Lower NRP

is the location of the NRP at a CCF other than the Highest CCF that serves the DA.

NOTE: In relation to the transition to Deployment State B this may include a proposed Lower NRP.

Lowest Asymmetric System Feed Point

is the point identified in accordance with Clause 7.7 of Part 1 of this IMP.

Metallic Path Facility

means a pair of twisted copper conductors between the relevant demarcation point at the End User's premises and the relevant demarcation point at a Telecom local exchange or Active Cabinet that conveys signals when connected to an electronic communications network.

MPF – End User Reference Point

is the End User end of the MPF.

MPF Loop Trace

is a list of all the lengths, types, gauges and dispositions of all the in line Communications Wire segments.

MPF – Network Reference Point

is the network end of the MPF.

NOTE: For a system operated by an Access Seeker, the MPF – NRP will be the HDP. For a system operated by Telecom, the MPF – NRP will be the point at which Telecom gains access to the MPF for its own services.

Nominated Lower NRP

is the Lower NRP that is nominated for the purposes of Deployment State B.

NOTE: The process for nominating this point is not addressed in this IMP (see Clause 7.5.6 of Part 1 of this IMP). The definition of Deployment State B in Clause 7 of Part 1 of this IMP assumes the existence of a Nominated Lower NRP.

Non-Deployment Class System

means a system that is not a Deployment Class System.

Pair Separation

is the allocation of pairs of Communication Wires for two Deployment Classes (a) into separate Cable Units in unit cable or (b) with pair number differing by 10 or more in quad cable.

Point of Interconnection with respect to the MPF

is the HDP in the case of an Access Seeker, and, in the case of Telecom, is the point at which Telecom connects to the MPF in an exchange or an Active Cabinet.

Power Feeding over the MPF

is the practice of powering equipment remotely using the MPF.

Plain Old Telephone Service

means a telecommunications service for the purpose of voice telephony (excluding ISDN and VoIP), voiceband modem or facsimile.

Service Provider

means Telecom or any provider of a telecommunications service who is using the UCLL Service or any sub loop unbundling service.

SDSL

is an older variable rate 2B1Q line coded system with similar characteristics to HDSL.

Spectral Compatibility Benchmark

is the determined relationship for a Basis System between bit rates achievable in each direction and range (expressed as a single range for a fixed rate system) for an error rate of 10^{-7} with a margin of 6dB in the 1% worst case crosstalk environment.

NOTE: The 1% worst case crosstalk environment is defined in Clause 5 of Part 2 of this IMP.

Spectral Compatibility Benchmark I

is a Spectral Compatibility Benchmark for a Basis System operating from either:

- (1) the highest NRP in Deployment State A; or
- (2) the nominated lower NRP in Deployment State B.

NOTE: Refer to Clause 4 of Part 2 of this IMP for more information on the determination of Spectral Compatibility Benchmark I.

Spectral Compatibility Benchmark II

is a Spectral Compatibility Benchmark for a Basis System operating from the highest NRP in Deployment State B.

NOTE: Refer to Clause 4 of Part 2 of this IMP for more information on the determination of Spectral Compatibility Benchmark II.

Spectral Compatibility Determination Process

means the process contained in Part 2 of this IMP for determining spectral compatibility of systems operated using MPFs

Spectral Compatibility Model

means the model developed in Australia by ACIF for the purpose of determining whether or not the operation of a system will cause Unacceptable Interference into a Basis System.

Spectrally Asymmetric

means using different PSD for transmission in each direction.

Spectrally Symmetric

means using the same PSD for transmission in each direction.

Subscriber Multiplexer

Is a device that provides ring tone, ring current and battery feed to End Users' equipment. Examples are Remote Subscriber Multiplexers, Remote Line Units and the End User line module of a local exchange.

Trial System or Extraordinary and Temporary Use System

is a system that is operated in accordance with Clause 8.6 of Part 1 of this IMP.

UCLL Standard Terms

means the terms set out in the Network Services Standard Terms for Telecom's unbundled copper local loop network service including the UCLL General Terms and all of the schedules to the UCLL General Terms (as amended from time to time).

Unacceptable Excess Power

has the meaning given in Clause 8.2.3 of Part 1 of this IMP.

Unacceptable Interference into a Basis System

has the meaning given in Clause 8.2.2 of Part 1 of this IMP.

Voice Band

refers to those frequencies from DC to 4kHz.

xDSL

refers to different variations of a family of Digital Subscriber Line (DSL) technologies, such as ADSL, ADSL2+, HDSL, SHDSL, VDSL and similar technologies that provide a high bandwidth digital connection over an MPF.

6 (UNUSED)

7 REFERENCE ARCHITECTURE FOR SERVICES USING THE MPF

7.1 Background

7.1.1 This IMP recognises that POI-MPFs can only be established in a limited set of locations for any given Exchange Serving Area within the local loop. Figure 7-1 below shows the simplest case of an end-to-end service operating from a single POI-MPF located at the local exchange. In Figure 7-1 the Lower CCFs are shown as potential POI-MPFs.

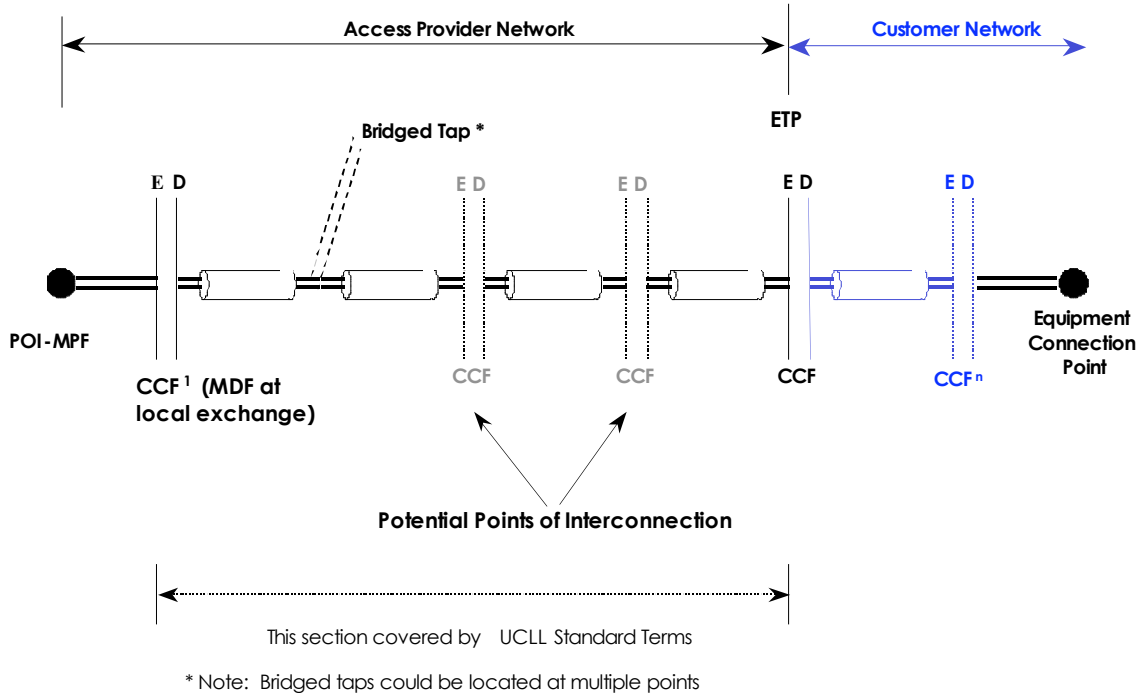

FIGURE 7-1

Schematic Diagram of an End-to-End Service Using the MPF

- 7.1.2 Each CCF may feed multiple CCFs, and may be fed from multiple CCFs.
- 7.1.3 Each Communications Wire may also branch at any point into two (or more) Communications Wires, thus forming a 'bridged tap' when one of the branches is used to provide the MPF.
- 7.1.4 The reference architecture caters for different services and different service types with different POI-MPFs. The ability to describe and distinguish between different POI-MPFs for services carried by pairs within the same Cable Unit is necessary for the development of spectral compatibility guidelines.
- 7.1.5 The Communications Wire used to provide the MPF may be made up of multiple sections of cables of different types between the Highest CCF and the ETP. Each section may be of a different cable type (i.e. conductor, insulation, and/or sheath material may differ) as well as conductor gauge and pair arrangement (i.e. layered, paired, quad, etc.). The cable pair count may also differ.

7.2 MPF Reference Architecture

7.2.1 Figure 7-2 below shows a schematic diagram of the MPF Reference Architecture.

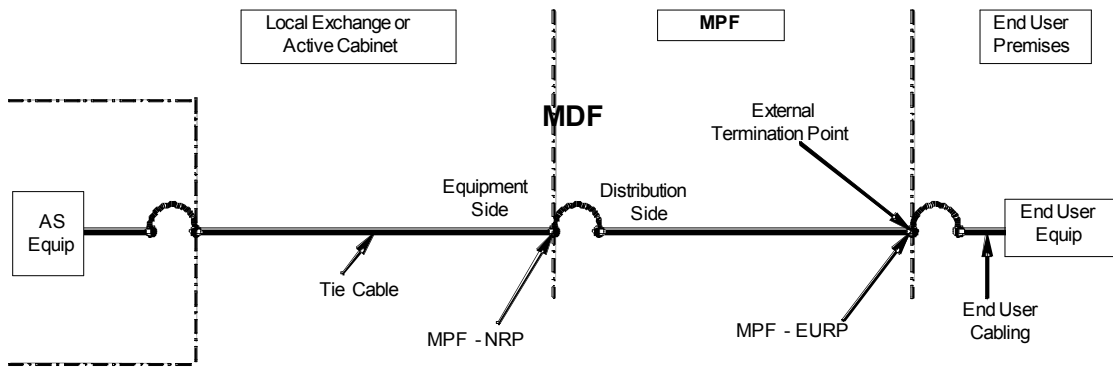

FIGURE 7-2

Schematic Diagram of the MPF Reference Architecture

7.3 Single and Multiple Feed Distribution Areas

7.3.1 The local loop environment is made up of multiple DAs within an ESA. Traditionally, a combination of main, branch and distribution cable connected the local exchange to each DA, and distribution cable used within each DA, as shown in Figure 7-3.

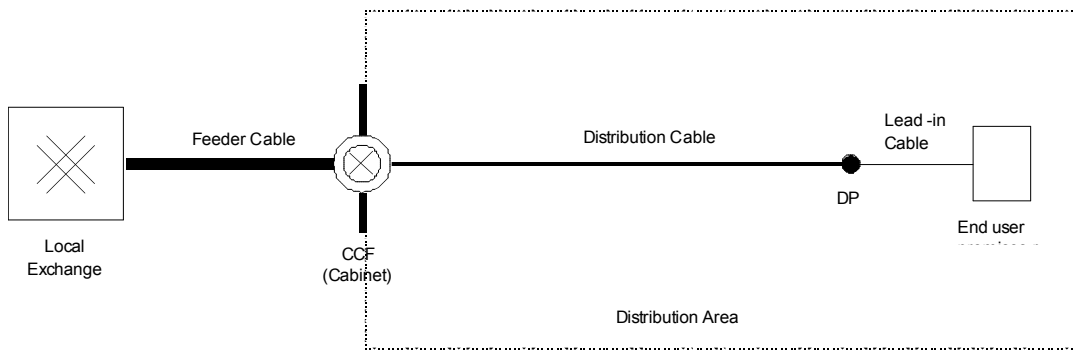

FIGURE 7-3

Schematic Diagram of the Traditional Local Loop

7.3.2 Any particular DA may be fed from either MPF-NRPs at a single location (single feed) or from MPF-NRPs at more than one location (multiple feed).

7.3.3 Single feed applies where systems in a particular DA are fed from MPF-NRPs at a single location. This may be at the MDF of the local exchange in the case of a DA connected by main and/or branch cable, or at a CCF associated with a kerbside facility such as an Active Cabinet where the DA is connected by optic fibre. Two examples of single feed DAs are shown in Figures 7-4 and 7-5.

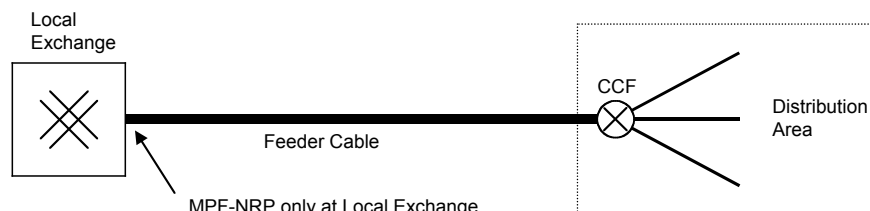

FIGURE 7-4

Example 1: Single Feed DA with MPF-NRPs at the Local Exchange

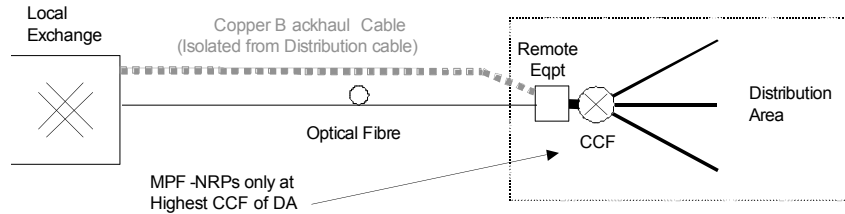

FIGURE 7-5

Example 2: Single Feed DA with MPF-NRPs at an Active Cabinet

7.3.4 Multiple feed applies where systems in a particular DA are fed from MPF-NRPs at more than one location. The Highest NRP is located at the Highest CCF (e.g. at the local exchange) and Lower NRPs are located at Lower CCFs (e.g. at an Active Cabinet). Figure 7-6 shows an example of multiple feed, where MPF-NRPs at two locations serve a DA.

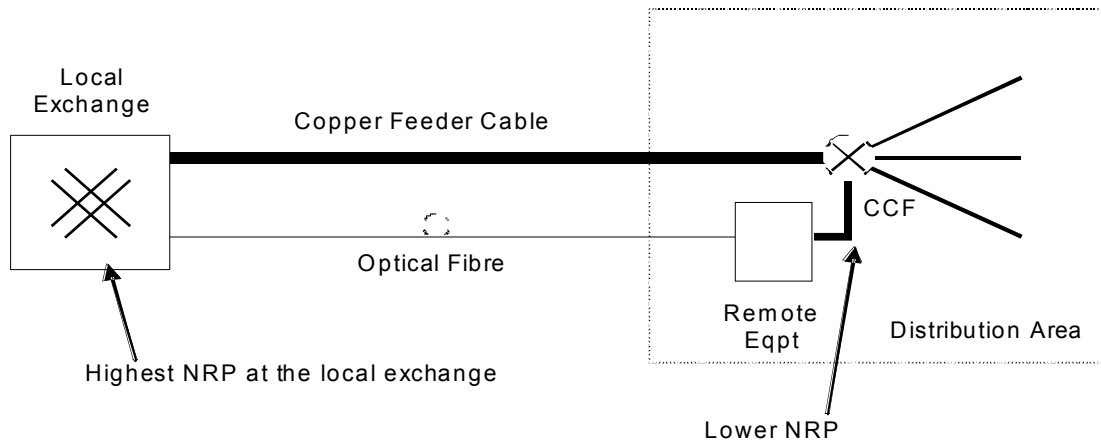

FIGURE 7-6

Example 3: Multiple Feed: MPF-NRPs at two locations serving a single DA

7.4 Performance Implications of Single and Multiple Feed DAs

- 7.4.1 For the single feed DA, all systems operating in that DA are fed from the Highest NRP. In this network case, problems with differing transmit levels on adjacent communications wires are avoided.
- 7.4.2 In contrast, for the multiple feed DA:
 - (1) there is potential for unequal level crosstalk interference from Spectrally Asymmetric Systems fed from Lower NRPs to degrade the performance of Spectrally Asymmetric Systems fed from the Highest NRP;
 - (2) Spectrally Symmetric Systems fed from the Highest NRP are not expected to be degraded by crosstalk interference from any systems fed from Lower NRPs.

7.5 Deployment States A and B

7.5.1 This IMP categorises every DA as being in either Deployment State A or Deployment State B. The categorisation of a DA as Deployment State A or

Deployment State B is relevant for determining Spectral Compatibility Benchmarks for Basis Systems.

NOTE: See Clause 8.2.2 of Part 1 of this IMP which provides the performance requirements for the particular Deployment State.

- 7.5.2 A Single Feed DA is always in Deployment State A. A Multiple Feed DA may be in Deployment State A or Deployment State B.
- 7.5.3 A DA is in Deployment State A unless it is in Deployment State B.
- 7.5.4 Deployment State B is the default state for all Multiple Feed Active Cabinets.
- 7.5.5 A DA is in Deployment State B where a particular Lower NRP is nominated for the DA, viz. the Nominated Lower NRP. The Nominated Lower NRP is the Lowest Asymmetric System Feed Point in Clause 7.7.3 of Part 1 of this IMP.
- 7.5.6 The process for nominating the Nominated Lower NRP and the transition to Deployment State B is not addressed in this Code. It is the intention of Service Providers that:
 - (1) the process for nominating the Nominated Lower NRP and the Transitional Arrangements be addressed as part of bilateral agreements with the AP; and
 - (2) the Transitional Arrangements be completed before Deployment State B takes effect for a particular DA.

7.6 Deployment Reference Points

- 7.6.1 For a system operated in a DA that is in Deployment State A, the Deployment Reference Point is:
 - (1) for a Deployment Class System, at the Highest NRP;
 - (2) for a Non-Deployment Class System, the reference point nominated by the Service Provider under Clause 8.4.4 of Part 1 of this IMP.
- 7.6.2 For a system operated using the MPF in a DA that is in Deployment State B, the Deployment Reference Point is:
 - (1) for a Deployment Class System, the Deployment Reference Point corresponding to the applicable Deployment Class;
 - (2) for a Non-Deployment Class System, the reference point nominated by the Service Provider under Clause 8.4.4 of Part 1 of this IMP.

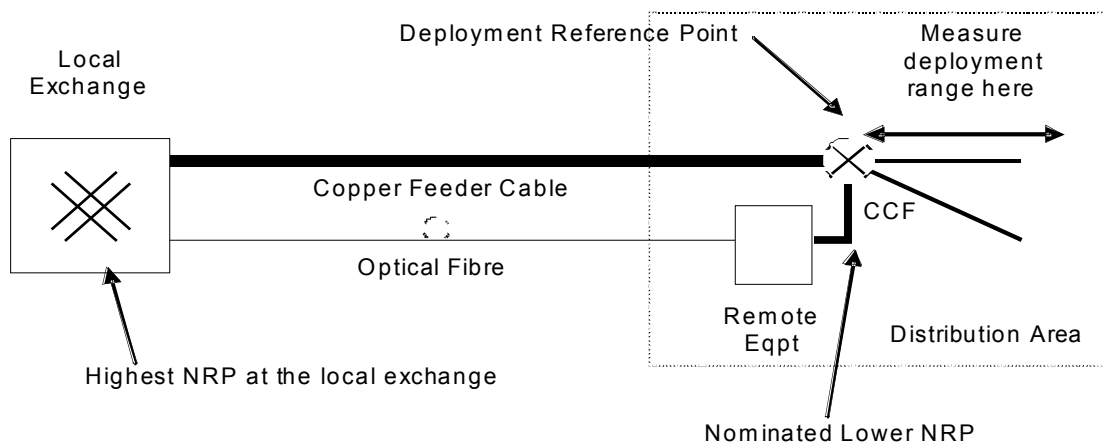

FIGURE 7-7

One possible location of Deployment Reference Point at Nominated Lower NRP in Deployment State B.

7.7 Lowest Asymmetric System Feed Point

7.7.1 The Lowest Asymmetric System Feed Point is the lowest point from which a Spectrally Asymmetric System may be fed.

NOTE: Feeding any Spectrally Asymmetric System from a lower point causes Unacceptable Interference into a Basis System.

7.7.2 For a system operated in a DA that is in Deployment State A, the Lowest Asymmetric System Feed Point is:

- (1) for a Deployment Class System, at the Highest NRP;
- (2) for a Non-Deployment Class System, the reference point nominated by the Service Provider under Clause 8.4.4 of Part 1 of this IMP.

7.7.3 For a system operated using the MPF in a DA that is in Deployment State B, the Lowest Asymmetric System Feed Point is:

- (1) for a Deployment Class System, the Nominated Lower NRP;
- (2) for a Non-Deployment Class System, the reference point nominated by the Service Provider under Clause 8.4.4 of Part 1 of this IMP.

8 PERFORMANCE REQUIREMENTS FOR OPERATION OF SYSTEMS USING THE MPF

8.1 General

- 8.1.1 Clause 8 of Part 1 of this IMP imposes performance requirements on systems operating on the MPF in order to:
- (1) control interference into systems carried in the same cable sheath where the disturbed system is of the same type as a Basis System; and
 - (2) maximise the efficient use of the MPF spectrum.
- 8.1.2 Management of interference between systems operated using the MPF is affected by a number of characteristics of the systems. The characteristics that have been identified in the development of this IMP include:
- (1) transmit PSD;
 - (2) maximum aggregate transmit pass band power;
 - (3) longitudinal output voltage;
 - (4) longitudinal balance; and
 - (5) deployment range.
- 8.1.3 The concepts of Unacceptable Interference into a Basis System and Unacceptable Excess Power are used in this IMP as the basis for the obligations on Service Providers' operating systems using the MPF. These concepts are based on the Spectral Compatibility Determination Process described in Part 2 of this IMP. It should be noted that ensuring that a system does not cause Unacceptable Interference into a Basis System does not guarantee a level of performance for any deployed system.

NOTE 1: Limiting Unacceptable Interference into a Basis System ensures that all Basis System types have an error rate less than 1 in 10^{-7} in the 1% worst case crosstalk environment. Basis Systems are idealised systems that correspond to several particular system types that are operated using the MPF.

NOTE 2: Limiting Unacceptable Excess Power avoids the use of spectrum prior to the consideration of the most efficient use of that spectrum in the operation of systems using the MPF.

- 8.1.4 To facilitate the deployment and operation of systems using the MPF, this IMP sets out Deployment Classes and associated Deployment Rules that, if complied with, ensure that the requirements of this IMP are met.
- 8.1.5 This IMP provides for separate processes for determining compliance with the IMP in relation to operation of systems:
- (1) that correspond to a Deployment Class contained in Part 3 of this IMP ('Deployment Class Systems'); and
 - (2) that do not correspond to a Deployment Class ('Non-Deployment Class Systems').

NOTE: These processes are set out in Clauses 8.3 and 8.4 of Part 1 of this IMP respectively.

- 8.1.6 The Deployment Classes contained in Part 3 of this IMP address, inter alia, the characteristics listed in Clause 8.1.2 of Part 1 of this IMP in order to avoid Unacceptable Interference into a Basis System from systems that are within a Deployment Class.

NOTE: See Clause 8.3 of Part 1 of this IMP.

- 8.1.7 The effect of the Deployment Classes in determining Unacceptable Interference into a Basis System and Unacceptable Excess Power is dependent on the End User equipment being used in connection with the Service Provider's system meeting the requirements of the International Standard for the corresponding Deployment Class defined in Appendix A of Part 3 of this IMP and the relevant PTC.

NOTE: Clause 8.3.2 of Part 1 of this IMP provides that a system is taken to be complying with the requirements of a Deployment Class only if the End User equipment used in connection with the system meets the requirements of the corresponding equipment class.

- 8.1.8 In order to demonstrate that the operation of Non-Deployment Class Systems meet the requirements of this IMP, a Service Provider that proposes to operate a Non-Deployment Class System must use the Spectral Compatibility Determination Process as contained in Part 2 of this IMP to demonstrate that both Unacceptable Interference into a Basis System and Unacceptable Excess Power do not occur.

NOTE: See Clause 8.4 of Part 1 of this IMP.

8.2 Rules for Operation of Systems using the MPF

- 8.2.1 An Service Provider must not operate a system using the MPF if the system causes:
- (1) Unacceptable Interference into a Basis System; or
 - (2) Unacceptable Excess Power.

NOTE 1: Clause 8.2.1 of Part 1 of this IMP applies to both Deployment Class Systems and Non-Deployment Class Systems.

NOTE 2: Clause 8.2.2 of Part 1 of this IMP provides that the assessment of whether a system operated using MPF causes Unacceptable Interference into a Basis System is dependent on whether the disturbing system is being operated in a DA that is either in Deployment State A or Deployment State B.

NOTE 3: For Deployment Class Systems, Clause 8.3 of Part 1 of this IMP provides the only means of ensuring compliance with the obligation in 8.2.1 of Part 1 of this IMP.

NOTE 4: For Non-Deployment Class Systems, Clause 8.4 of Part 1 of this IMP provides the only means of ensuring compliance with the obligation in 8.2.1 of Part 1 of this IMP.

NOTE 5: Clause 9 of Part 1 of this IMP prohibits a person from operating a system if the system uses power feeding equipment that does not comply with certain safety requirements.

- 8.2.2 For the purposes of Clause 8.2.1(1) of Part 1 of this IMP and clause 48 of the UCLL General Terms, a system ('the disturbing system') causes Unacceptable Interference into a Basis System if:
- (1) for a system that is operated in a DA that is in Deployment State A, the disturbing system causes crosstalk interference that degrades the performance of any Basis System fed from the Highest NRP below its Spectral Compatibility Benchmark I as specified in Clause 4.1.1 of Part 2 of this IMP; or
 - (2) for a system that is operated in a DA that is in Deployment State B, the disturbing system causes crosstalk interference that degrades the performance of:
 - (a) any Spectrally Asymmetric Basis System fed from the Highest NRP below its Spectral Compatibility Benchmark II as specified in Clause 4.2.1 of Part 2 of this IMP; or

- (b) any Basis System fed from the Nominated Lower NRP below its Spectral Compatibility Benchmark I as specified in Clause 4.1.1 of Part 2 of this IMP.

NOTE: Clause 2.3 of Part 2 of this IMP defines the configurations and conditions under which Unacceptable Interference into a Basis System is determined.

- 8.2.3 For the purposes of Clause 8.2.1(2) of Part 1 of this IMP and clause 48 of the UCLL General Terms, a system causes Unacceptable Excess Power if the system transmit PSD or the maximum aggregate power transmitted does not satisfy the requirements of Clause 2.4 of Part 2 of this IMP.

NOTE: Clause 8.4.5(2) of Part 1 of this IMP provides that, for a Non-Deployment Class System, a Service Provider must use the maximum transmit PSD mask (at the MPF-NRP and MPF-EURP) that they have supplied to all Service Providers currently using MPFs to determine whether the system causes Unacceptable Excess Power. Clause 2.4 of Part 2 of this IMP sets out the requirements in respect of Unacceptable Excess Power.

8.3 Operation of Deployment Class Systems

- 8.3.1 Clause 8.3 of Part 1 of this IMP provides the only means of demonstrating compliance with the obligation in Clause 8.2.1 of Part 1 of this IMP for a Deployment Class System.

NOTE: Part 3 of this IMP lists Deployment Classes and indicative technologies that correspond to those Classes. The Deployment Classes are grouped according to indicative technologies (e.g. E1 HDB3, ISDN BR 2B1Q, ADSL, ADSL over ISDN, SHDSL).

- 8.3.2 A Service Provider that operates a Deployment Class System must meet each of the following conditions in order to comply with Clause 8.2.1 of Part 1 of this IMP:

- (1) the operation of the network equipment and End User equipment is in accordance with the requirements of the applicable Deployment Class;
- (2)
- (3) the operation of the system is in accordance with the Deployment Rules for the applicable Deployment Class set out in Part 3 of this IMP.

NOTE: Appendix A to Part 1 of this IMP shows the method of complying with the Deployment Limit requirements applicable to Deployment Classes.

8.4 Operation of Non-Deployment Class Systems

- 8.4.1 Clause 8.4 of Part 1 of this IMP provides the only means of complying with the obligation in Clause 8.2.1 of Part 1 of this IMP for a Non-Deployment Class System.

- 8.4.2 In determining whether the operation of a Non-Deployment Class System causes Unacceptable Interference into a Basis System a Service Provider must:

- (1) use the Spectral Compatibility Determination Process; and
- (2) use the Spectral Compatibility Model.

NOTE: The Spectral Compatibility Determination Process and the Spectral Compatibility Model are contained in Part 2 of this IMP.

- 8.4.3 A Service Provider must not operate a Non-Deployment Class System using the MPF if:

- (1) the parameters specified in Clause 8.4.4 of Part 1 of this IMP have not been provided to all other Service Providers; or

- (2) the operation of the system causes any of the masks, values or limits supplied to all other Service Providers under Clauses 8.4.4(1), (2), (3) and (6) of Part 1 of this IMP to be exceeded; or
- (3) the MPF does not have the required pair separation notified to all other Service Providers under Clause 8.4.4(4) of Part 1 of this IMP; or
- (4) the system equipment longitudinal output voltage exceeds the mask supplied to all other Service Providers under Clauses 8.4.4(7) of Part 1 of this IMP, or the longitudinal balance is below the mask supplied to all other Service Providers under Clause 8.4.4(8) of Part 1 of this IMP; or
- (5) the system transmit PSD does not satisfy the requirements of Clause 2.4 of Part 2 of this IMP.

NOTE 1: Pair separation may be required to ensure that the operation of a system does not cause Unacceptable Interference into a Basis System. In this case, the requirement for pair separation arises as a result of using the process described in Part 2 of this IMP.

NOTE 2: Where a proposed system would be utilising spectrum outside of the existing Basis Systems the service provider may propose a change to the IMP in accordance with Clause 48 of the UCLL General Terms.

NOTE 3: Clause 8.4.4 of Part 1 of this IMP sets out the information required for determining whether a Non-Deployment Class System will cause Unacceptable Interference to a Basis System.

- 8.4.4 For the purpose of Clause 8.4.3 of Part 1 of this IMP, the details that must be provided to all other Service Providers are maximum transmit PSD masks at the MPF-NRP and the MPF-EURP, and maximum aggregate transmit pass band power at the MPF-NRP and the MPF-EURP.

NOTE: Transmit PSD masks and aggregate transmit power may include power cut back specification.

- (1) proposed maximum Deployment Limit from the Deployment Reference Point specified in (5) and reference frequency;
- (2) proposed pair separation at the network end from Deployment Class 1 (b) systems; and

NOTE: See Clause 8.4.3(3) of Part 1 of this IMP above.

- (3) if the Deployment Reference Point for the proposed system is not the Highest NRP, the proposed locations of Deployment Reference Points for operation of the system in Deployment State A and Deployment State B;

NOTE: Each Deployment Reference Point needs to be specified relative to either the Highest NRP or the Nominated Lower NRP. If the information is not supplied, the DRP will default to the Highest NRP.

- (4) if the proposed system is a Spectrally Asymmetric System, the Lowest Asymmetric System Feed Point from which the Service Provider proposes to feed the system in each of Deployment State A and Deployment State B.

NOTE: The points referred to in (6) need to be specified relative to either the Highest NRP or the Nominated Lower NRP. For example, either at one of these locations or at a specified calculated attenuation therefrom. If the information is not supplied, the Lowest Asymmetric System Feed Point defaults to the Highest NRP in Deployment State A and the Nominated Lower NRP in Deployment State B.

- (5) maximum longitudinal output voltage masks for network equipment and End User equipment;

- (6) minimum longitudinal balance masks for network equipment and End User equipment.

NOTE 1: The details referred to in (1) through to (8) are intended to correlate with information used in the definition of Deployment Classes.

NOTE 2: Clause 8.4.3 of Part 1 of this IMP provides that the operation of a Deployment Class system must not exceed any of the masks, values or limits supplied under Clause 8.4.4 of Part 1 of this IMP.

NOTE 3: The determination of compliance with Deployment Limits for Non-Deployment Class Systems uses the same method as for Deployment Class Systems in Appendix A.

NOTE 4: For a Non-Deployment Class System with specified filter attenuation as described by 8.4.4(1)(b) of Part 1 of this IMP, it may be sufficient to reference the relevant requirement of the nominated Deployment Class for any of 8.4.4 (2) to (8) of Part 1 of this IMP that is already compliant.

8.4.5 For the purposes of Clause 8.4.4 of Part 1 of this IMP:

- (1) the parameters supplied under Clause 8.4.4 of Part 1 of this IMP must be the parameters used in or derived as a result of using Clause 2.3 of Part 2 of this IMP to determine whether the system causes Unacceptable Interference into a Basis System. For a Non-Deployment Class System with specified filter attenuation as described by Clause 8.4.4(1)(b) of Part 1 of this IMP, the filter attenuation shall be subtracted from the relevant Nominal requirement for the specified Deployment Class to provide a modified crosstalk calculation template; and

Requirements for a Deployment Class are listed in the relevant Appendix to Part 3 of this IMP. Refer to Table A-1 in Appendix A of Part 3 of this IMP for a table of Deployment Classes.

- (2) the masks referred to in Clause 8.4.4(1) of Part 1 of this IMP must be used in the test contained in Clause 2.4 of Part 2 of this IMP to determine that the system does not cause Unacceptable Excess Power.

NOTE: Clause 8.2.1(2) of Part 1 of this IMP prohibits a person from operating a system if the system causes Unacceptable Excess Power.

8.5 Use of More Than One System Type on a single MPF

8.5.1 This Clause sets out the compliance requirements where a Service Provider is operating more than one system type using a single MPF.

8.5.2 Where a Service Provider is operating more than one system type on a single MPF and the system types operate only in separate time intervals then the operation of each system must comply with Clause 8.2 of Part 1 of this IMP.

NOTE: This case is expected to arise where line test equipment is used on a MPF.

8.5.3 Where a Service Provider is operating more than one system type on a single MPF and the systems do not operate in separate time intervals:

- (1) the systems constitute a composite system that corresponds to a Non-Deployment Class System; and
- (2) the operation of the composite system must comply with Clauses 8.2 and 8.4 of Part 1 of this IMP.

8.6 Trials and Extraordinary or Temporary uses

- 8.6.1 For the purposes of Clause 1.4 of Part 1 of this IMP, a Trial System or Extraordinary and Temporary Use System is a system that meets each of the requirements of Clause 8.6.2 of Part 1 of this IMP.

NOTE: Clause 1.4 provides that the operation of a Trial or Extraordinary and Temporary Use that meets the requirements of Clause 8.6.2 of Part 1 of this IMP is not subject to the obligations in Clause 8.2.1 of Part 1 of this IMP.

- 8.6.2 A system is a Trial System or Extraordinary and Temporary Use System if the operation of the system meets each of the following conditions:
- (1) Telecom believes on reasonable grounds that the Trial or Use does not:
 - (a) compromise the integrity of a telecommunications network or facility;
or
 - (b) compromise the health or safety of persons operating, working on, using or otherwise likely to be affected by the operation of a telecommunications network or facility;
 - (2) where the operation of the system will cause Unacceptable Interference into a Basis System or Unacceptable Excess Power, each affected party has given consent to the operation of the system; and
 - (3) where the use is extraordinary or temporary (but not a trial):
 - (a) the use does not exceed 30 days; or
 - (b) each affected party has given consent to a use that will exceed 30 days.

NOTE 1: In practice, use of the above trial or extraordinary or temporary use provisions set out above will only be necessary where the operation of the system would otherwise breach Clause 8.2 of Part 1 of this IMP.

NOTE 2: Consent to an extraordinary or temporary use that will exceed 30 days may be given prior to or during the use.

- 8.6.3 For the purposes of 8.6.2 of Part 1 of this IMP an affected party is a Service Provider that is operating or proposing to operate a Compliant System carried in the same cable sheath as the proposed Trial System or Extraordinary and Temporary Use System.

9 POWER FEEDING OF REMOTE EQUIPMENT USING THE MPF

9.1 Overview

- 9.1.1 This clause prescribes safety requirements that apply where a Service Provider operates a system that uses power feeding for remote equipment connected to the MPF.
- 9.1.2 A Service Provider must take reasonable steps to ensure that power feeding arrangements do not endanger the health or safety of persons that install, operate or maintain or otherwise come into contact with the MPF and any derived telecommunications service.

9.2 General Requirements of Power Feeding Equipment connected to MPF

- 9.2.1 9.2.1 A Service Provider must not operate a system with a remote power feeding capability unless the power feeding voltage does not exceed the TNV-3 limits of AS/NZS 60950.1

9.3 Safety Requirements for Power Feeding into End User Premises

- 9.3.1 All equipment must be installed and maintained in a manner to minimise the likelihood of unintentional contact by service personnel or bridging of bare power feeding parts.
- 9.3.2 Where possible, exclusive Service Provider cabling should be used to bypass End User-cabling distributors and restrict access to power feeding line conductors.
- 9.3.3 RFT line conductors used to extend power feed circuits into the End User premises should terminate directly on the power feeding or power fed equipment. Under no circumstances shall connectors (i.e. 4, 6 or 8-way modular connectors) that are used to connect End User equipment be used to connect power feed circuits.
- 9.3.4 All customer-premises cabling records must describe the pair usage as 'Warning: Power Feeding Telecommunications'.

10 COMPLIANCE WITH PERFORMANCE REQUIREMENTS UNDER THIS IMP

10.1 Overview

- 10.1.1 The Access Seeker and Telecom have complementary roles in complying with this IMP. This clause sets out how an Access Seeker and Telecom must demonstrate compliance.

10.2 Responsibility for Compliance

- 10.2.1 It is the responsibility of the Service Provider to ensure that the system operated on the MPF always complies with all of the requirements in the IMP.

10.3 Compliance with Deployment Class Requirements

- 10.3.1 There are three alternative ways by which compliance may be demonstrated in order to confirm that a system is being operated in accordance with the requirements of a Deployment Class. These ways are:

- (1) certified compliance with a listed international standard; or
- (2) laboratory compliance of systems; or
- (3) operational compliance of systems.

10.4 Standards Compliance

- 10.4.1 Certified compliance with an international standard is acceptable. The system must comply with the international standard listed under the Compliance Requirements for that Deployment Class in the relevant Appendix of Part 3 of this IMP.

10.5 Laboratory Compliance

- 10.5.1 Laboratory compliance refers to compliance of a system when tested under laboratory conditions. To ensure that the system continues to comply at the MPF-NRP in operation (as required by this IMP), the Service Provider must ensure that any allowances made for tie cables and for variations between systems and with temperature are correctly accounted for.
- 10.5.2 For laboratory compliance, measurements must be conducted in a controlled environment in accordance with Appendix B of Part 1 of this IMP.

10.6 Operational Compliance

- 10.6.1 Operational compliance refers to compliance when the system is operated on the MPF. Because this is specified at the MPF-NRP to which only Telecom has access, it will only be tested by Telecom.
- 10.6.2 For Deployment Class Systems operating on a MPF, the Service Provider must operate the specified Deployment Class system in accordance with the requirements for the applicable Deployment Class.
- 10.6.3 To demonstrate that the correct Deployment Class is being used, measurements may be made on an operational service on the MPF and without interruption as described in Appendix B of Part 1 of this IMP.

11 OPERATION OF SYSTEMS IN END USER PREMISES (INFORMATIVE)

- 11.1 Systems that are not operated using the MPF, but share End User cabling with systems operated using the MPF may cause excessive crosstalk.
- 11.2 It is therefore recommended that all non-MPF installations of Broadband systems (including LANs and all Deployment Classes other than 3a and 4a) should be kept in separate cable sheaths from MPF systems.
- 11.3 However, if sharing occurs it is recommended that those non-MPF broadband systems should be installed in the shared cable according to the Deployment Rules for MPF systems, based on the relevant Deployment Reference Point and Lowest Asymmetric System Feed Point within the access network. Hence the following Deployment Rules are recommended in shared cable within the End User premises:
- (1) Systems belonging to Spectrally Asymmetric Deployment Classes or LAN systems should not be deployed in shared cabling; and
 - (2) Systems belonging to Spectrally Symmetric Deployment Classes should only be used in shared cabling if the total attenuation from the Deployment Reference Point in the access loop to the most distant point in the End User premise is less than the Deployment Limit for that Deployment Class.

12 (UNUSED)

13 (UNUSED)

14 STATUTORY COMPLIANCE

- 14.1 If there is an inconsistency between a requirement of this IMP and a requirement imposed on a Service Provider by statute, the Service Provider will not be in breach of the requirement of this IMP in relation to any conduct that is necessary to ensure compliance with that statute.

APPENDIX A METHOD FOR DETERMINATION OF DEPLOYMENT LIMIT COMPLIANCE.

In order to determine whether a system on a mixed gauge access loop complies with the Deployment Limit for a Deployment Class or meets the equivalent requirement of 8.4.4 (3), the following calculations shall be performed. The calculation is based on the MPF Loop Trace. An example of a MPF Loop Trace is shown in Table A-1.

Segment Number	Cable Type	Length (m)	Segment Type
1	0.63 PEFUT	2100	Inline
2	0.63 PEFUT	500	Inline
3	0.40 PEFUT	250	Inline

TABLE A-1

Example of MPF Loop Trace Information

From the MPF Loop Trace, the Calculated Attenuation of the access loop is compared with the Deployment Limit using the following steps.

1. The attenuation (in dB at the relevant reference frequency for the Deployment Class - see Table A-1) of each cable segment is determined by calculation from the cable parameters and formulae below;
2. The attenuations of all inline segments between the Deployment Reference Point and the MPF-EURP are summed to give the Calculated Attenuation. The Calculated Attenuation of the access loop of n segments each with length l_i km at frequency f kHz is obtained from the sum of the attenuations of all inline segments in the MPF Loop Trace:

$$\text{Calculated Attenuation}(f) = \sum_{i=1}^n l_i \times \text{Attenuation}_i(f) \quad (\text{dB}); \text{ and}$$

3. The Calculated Attenuation is then compared with the specified Deployment Limit for the Deployment Class. The test for compliance with the Deployment Limit is that the Calculated Attenuation does not exceed the Deployment Limit D_k for the relevant Deployment Class k at the specified reference frequency f_{ref} kHz for that class:

$$\text{Compliant if } \text{Calculated Attenuation}(f_{ref}) \leq D_k \quad (\text{dB})$$

For each cable in the access network the attenuation at each of the reference frequencies for the Deployment Classes is given in Table A-2.

Cable Type		Frequency (kHz)		
		40	160	1024
Paper Quad	0.40 PCQL		11.2	
	0.50 PCQL		8.1	
	0.63 PCQL		6.1	
	0.90 PCQL		4.4	
	0.50 PCQT		7.4	
	0.63 PCQT		5.6	
	0.90 PCQT		4.1	
	1.27 PCQT		3.0	
Paper Unit Twin	0.40 PCUT		11.8	
	0.50 PCUT		8.5	
	0.63 PCUT		6.5	
	0.90 PCUT		4.9	
Cellular Polythene Quad	0.40 (default)		11.4	
	0.50 (default)		8.5	
	0.63 (default)		6.1	
	0.90 (default)		4.1	
Barrier	0.40 PEUB		12.0	
	0.50 PEUB		8.9	
	0.63 PEUB		6.6	
	0.90 PEUB		4.9	
Cellular Polythene Unit Twin (unfilled)	0.40 CPUB		11.5	
	0.50 CPUB		8.2	
	0.63 CPUB		6.2	
	0.90 CPUB		4.6	
Cellular Polythene Unit Twin (filled)	0.40 PEFUT	6.3	9.5	22.2
	0.50 PEFUT		8.9	
	0.63 PEFUT		6.6	
	0.90 PEFUT		4.8	

Table A-2

Cable loss in dB/km for the different cable types and gauges at 160 kHz

APPENDIX B

MEASUREMENT METHODOLOGY

B.1 Introduction

B.1.1 Demonstrating Compliance

The methods for demonstrating compliance of systems with requirements specified in this IMP are described in Clauses B.2 to B.4 of Part 1 of this IMP.

Other methods may be used if the risk of non-compliance is not increased because of increased measurement uncertainty.

B.1.2 Non-continuous transmission

In order to appropriately represent for interference purposes the impact of short duration high power signals on the MPF, any signal which is transmitted on the MPF shall be treated as if it were continuously applied, with no reduction in measured average power or PSD based on the duty cycle. For example a time division duplex system which uses alternate bursts of signal power in each direction of transmission shall be treated as if each direction were operating continuously at the power levels used during the bursts. Also the use of short bursts of tone for any purpose (e.g. training, testing) shall be treated for compliance purposes as if that tone were continuously applied.

B.1.3 Record keeping

The prevailing conditions shall be recorded for each test to measure compliance including measurement uncertainty.

B.2 Test configurations for Laboratory Compliance

B.2.1 General

Test configurations used shall be outlined for each individual test. Test circuits other than those indicated in this IMP may be used but shall be documented.

B.2.2 Termination impedance

The termination impedance for tests must be as specified for the Deployment Class, or at the relevant impedance for the Non Deployment Class System. The accuracy of the terminating impedance must be taken into account when assessing the measurement uncertainty.

B.2.3 DC line current

Where a device is powered by DC line current, sources DC line current, or sinks or sources DC wetting current, the test conditions must be those which are normally present in use. The test circuits must provide the required current sources and sinks. The AC impedance of the source/sink must be taken into account in the estimation of measurement uncertainty. The balance of the source/sink must also be sufficient to allow the measurement of longitudinal balance.

B.2.4 Equipment state

For many of the tests it is necessary for the system under test to be placed in and maintained in a normal operational state without remote equipment connected. Where this is not possible with the equipment under test, laboratory tests must be performed with the remote equipment connected through high impedance bridging circuits as described for operational testing in clause B.4 of Part 1 of this IMP. Compliance may only be demonstrated within the accuracy of the line termination in such cases.

B.3 Laboratory Measurements

B.3.1 Total aggregate transmit power

New Zealand Copper Local Loop Interference Management Plan – Part 1 November 2007 PRELIMINARY	33
--	----

Total aggregate transmit power is measured using the test circuit in Figure B-1.

For a system which does not supply or sink DC line power, and does not source or sink wetting current, the DC blocking components and DC source/sink are not required.

The total aggregate transmit power must be measured with the system under test terminated in the termination impedance for the Deployment Class, or at the relevant impedance for the Non Deployment Class System

The total aggregate transmit power must be measured over the entire pass band for the Deployment Class or the appropriate pass band, which shall not be less than the Deployment Class pass band, for Non Deployment Class Systems. Note that selection of an appropriate pass band must be based on the need for adequate settling of instruments to provide an accurate power measurement. The measurement equipment must not be synchronous with the system.

The data input to the system under test must be a pseudo-random sequence, and the system must provide all processes used in normal operation (e.g. scrambling, coding). Pseudo-random sequences must be those specified in O.151, O.152 or O.153 for the appropriate data rate.

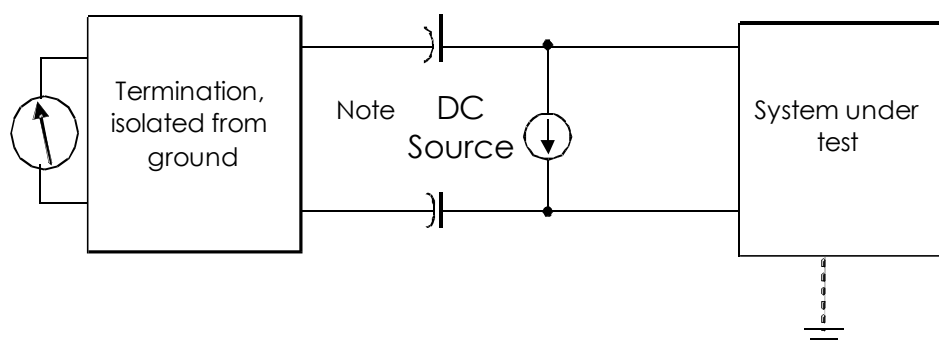

NOTE: The measurement uncertainty needs to take into account the accuracy of the differential termination, including the effect of the blocking capacitors and other equipment.

FIGURE B-1

Aggregate transmit power and PSD test configuration

B.3.2 Power Spectral Density

The PSD must be measured using the configuration in Figure B-1.

The data input to the system under test must be a pseudo-random sequence, and the system must provide all processes used in normal operation (e.g. scrambling, coding). Pseudo-random sequences must be those specified in the O.151, O.152 or O.153 for the appropriate data rate.

The PSD must be measured using the resolution bandwidths and frequency ranges where specified for the Deployment Class. For Non-Deployment Class Systems the PSD must be measured over a frequency range 0 – 12040 kHz with a resolution bandwidth not greater than 10kHz.

Measurements must be made at discrete frequencies, with a spacing equal to the resolution bandwidth, covering the range specified for the Deployment Class.

The measurement at each frequency must be averaged over a time which takes into account the settling time for the resolution bandwidth. For a measurement bandwidth of 10 kHz at least 2 seconds is required.

To obtain the dynamic range required in the measurement of some Deployment Classes, it may be necessary to use passive filters before the spectrum analyser or selective level meter

when measuring the out of band spectrum. If filters are used it is necessary to assure the nominal termination impedance is maintained across the whole signal band.

B.3.3 Longitudinal balance

Longitudinal balance is measured using the test circuit in Figure B-2.

The transmitter of the system under test must be placed in a quiet mode and the termination of the line by the system under test must be maintained.

The DC source/sink and blocking components are not required where the power feed or wetting current is not supported.

The system under test must be earthed as under normal operating conditions.

The residual balance of the test circuit must be at least 20 dB over the limit when a resistor of the termination impedance for the Deployment Class is substituted for the system under test.

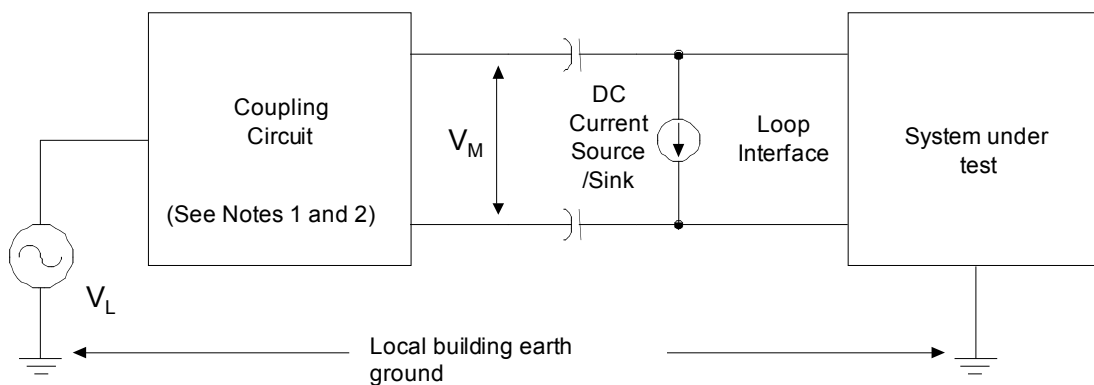

NOTE 1: The impedance of the metallic or differential termination of the coupling circuit is equal to the termination impedance for the Deployment Class, or for Non Deployment Class Systems, a specified value not less than 100 or greater than 150 ohm.

NOTE 2: The longitudinal or common mode termination of the coupling circuit is equal to 1/4 of the differential termination impedance in Note 1.

FIGURE B-2

Longitudinal balance measurement

B.3.4 Longitudinal output voltage

The longitudinal output voltage must be measured using the circuit in Figure B-3.

The DC source/sink and blocking components are not required where the power feed or wetting current is not supported.

The measurement equipment must not be synchronous with the system.

The data input to the system under test must be a pseudo-random sequence, and the system must provide all processes used in normal operation (e.g. scrambling, coding). Pseudo-random sequences must be those specified in the O.151, O.152 or O.153 for the appropriate data rate.

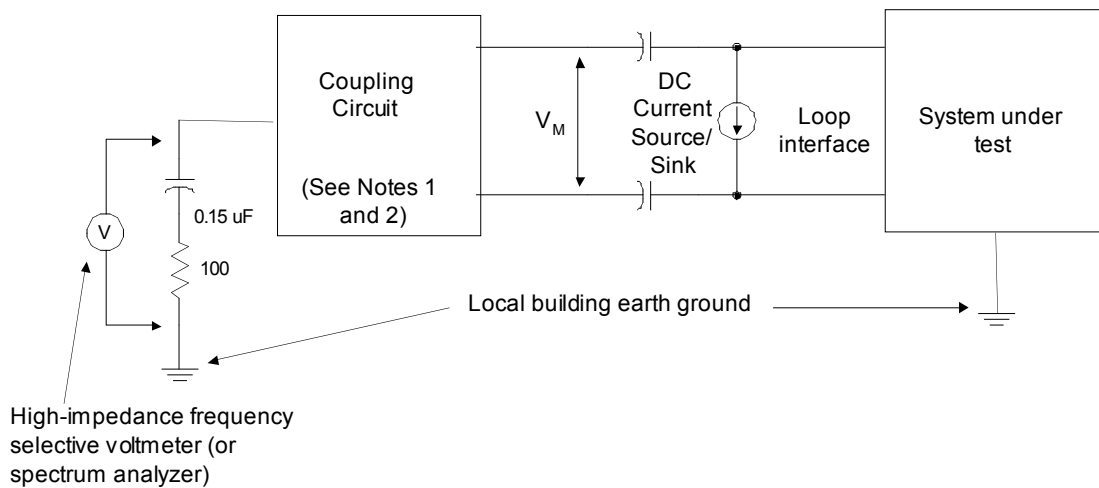

NOTE 1: The impedance of the metallic or differential termination of the coupling circuit is equal to the termination impedance for the Deployment Class, or for Non Deployment Class Systems, a specified value not less than 100 or greater than 150 ohm.

NOTE 2: The longitudinal or common mode impedance of the coupling circuit is equal to 1/4 of the differential termination impedance in Note 1.

FIGURE B-3

Longitudinal output voltage measurement

B.4 Operational Measurements

- B.4.1 Measurements on operational systems need to take into account the measurement uncertainty introduced by the inability to control the termination impedances and measurement environment. On an operational system, measurements of Total Average Power (2.3 of Part 3), Power Spectral Density (2.4 of Part 3) and Longitudinal Output Voltage (2.7 of Part 3) will be possible with reduced accuracy, but measurements of Longitudinal Balance (2.6 of Part 3) will not be possible.
- B.4.2 PSD measurements at the MPF-NRP, may be adversely affected by "ambient" noise on the tie cable between the MDF and the Service Provider's equipment. This "ambient" noise must be taken into account when measurements are made at the MPF -NRP.
- B.4.3 Longitudinal balance measurements may be adversely affected by the tie cable. By nature of the measurement, it can only be performed by interrupting a service. Measurement may need to be performed at the Service Provider's equipment as well to identify if there is a problem with the tie cable.
- B.4.4 Measurements made at the MPF-NRP or MPF-EURP need to take into account the measurement uncertainty at these points. The specifications in this section are for a termination of a resistive load for the class. Measurements made with a distribution network cable connected may result in a measurement uncertainty, due to the termination impedance, of sufficient magnitude for a measurement to be inconclusive in demonstrating compliance or non-compliance. Further measurement uncertainty is a result of the signal from the remote end.
- B.4.5 The transmit power spectral density measurements at the network end of operational systems shall be made at the MPF-NRP, and at the End User end at the MPF-EURP or the nearest practicable location.
- B.4.6 For operational measurements (or in laboratory measurements where the system under test requires the LT and NT to be connected to enable the system to continuously transmit, then the test set-up in Fig. B-4 must be used.

B.4.7 The method of measurement is as follows. With the switches in the calibrate position and using matching transformers with approximately the same impedance as the cable, measure the noise level from the noise source on a spectrum analyser or suitable power meter. Switch Calibrate Probe switch to Differential Probe position, and adjust the differential probe until the power measures the same as in the Calibrate position. The probe should now be calibrated. Switch to Measure and measure the PSD.

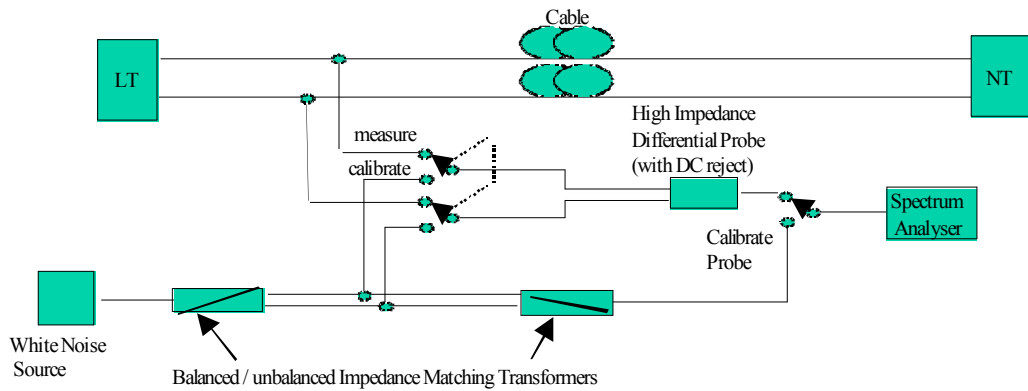

FIGURE B-4

Test Setup for Measurement of PSD when System transmit cannot be enabled

B.4.8 The minimum impedance to line for the high impedance differential probe shall be 10kΩ. A suitable high impedance bridging circuit is provided in ITU-T Recommendation G.991.2, Figure I-1.