

**From Hype to Reality  
An Overview of NGN  
(what it is and what it isn't)**

**Broadband at a Crossroads,  
February 2009**

**Peter Darling**

**Pondarosa Communications Pty Ltd**

# (Telco) Network Generations

<b>Fixed Network</b>	<b>Mobile</b>	<b>Data</b>
Analogue PSTN	Analogue Mobile (AMPS, NMT)	X.25 Packet
Digital PSTN	Digital Mobile (GSM, CDMAOne)	Frame Relay Internet
“Carrier Grade IP”	3G (CDMA2000, UMTS)	“Carrier Grade IP”

# The Next Generation Network (NGN)

From the ITU definition, an NGN:-

- Is packet-based (normally Internet Protocol);
- Makes use of multiple broadband, QoS-enabled transport technologies;
- Has service-related functions that are independent of the underlying transport-related technologies;
- It enables unfettered access to competing service providers; and
- Supports generalised mobility

# NGNs

- **NGNs are actually “now generation networks”;**
- **NGN standards are being developed by telco standards groups, building on IETF standards**
  - **ETSI TISPAN**
  - **ITU**
  - **3GPP**
- **NGNs create the potential for increased competition in the supply of services and applications**

**NGN**



**Broadband**

# Why NGN?

- **To replace current PSTN equipment**
  - **Circuit switched no longer being developed**
- **To save money (opex saving)**
- **To generate new revenue from new services**

**(loss of PSTN technical expertise through staff reductions, retirements etc)**

# The Internet Base

- **The Internet has no formal, standardised hierarchy**
- **Market forces tend to produce divisions such as**
  - **ISPs serving customers (“retail ISP”)**
  - **National transit providers**
  - **International transit providers (“backbone providers”)**

**But things change rapidly**

# Internet Operation (Very simplified)

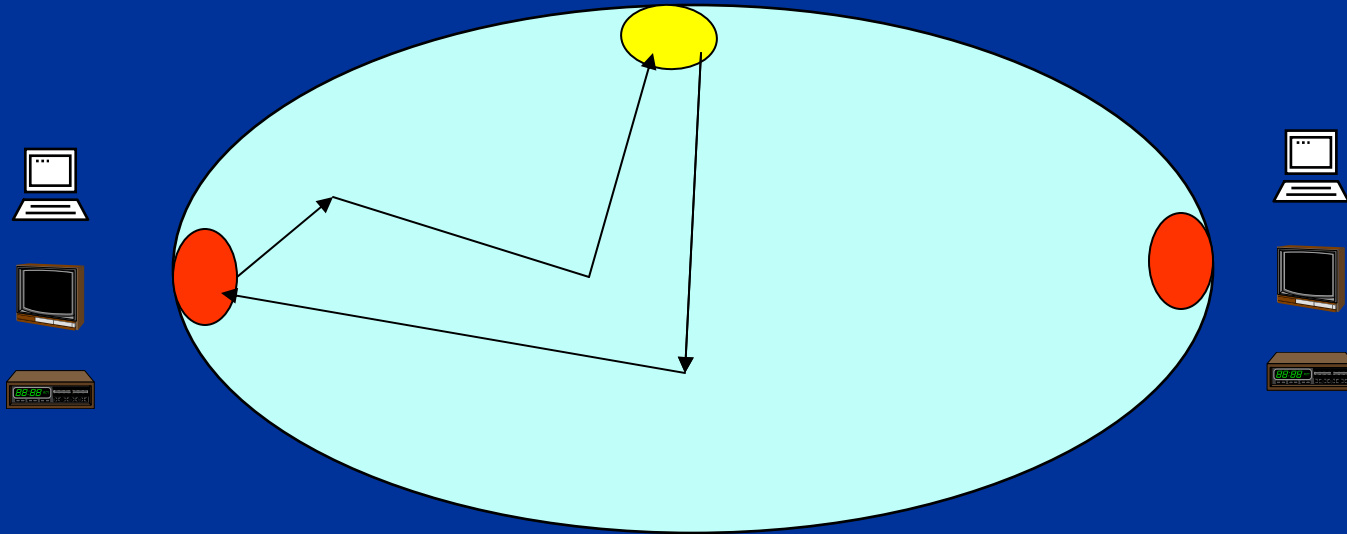

- User enters required destination **peter.darling@pondarosa.com**
- The Domain Name System returns the current IP address (e.g. for **pondarosa.com**)
- The user's equipment prepares the first packet to send to this address

**(Very simplified)**

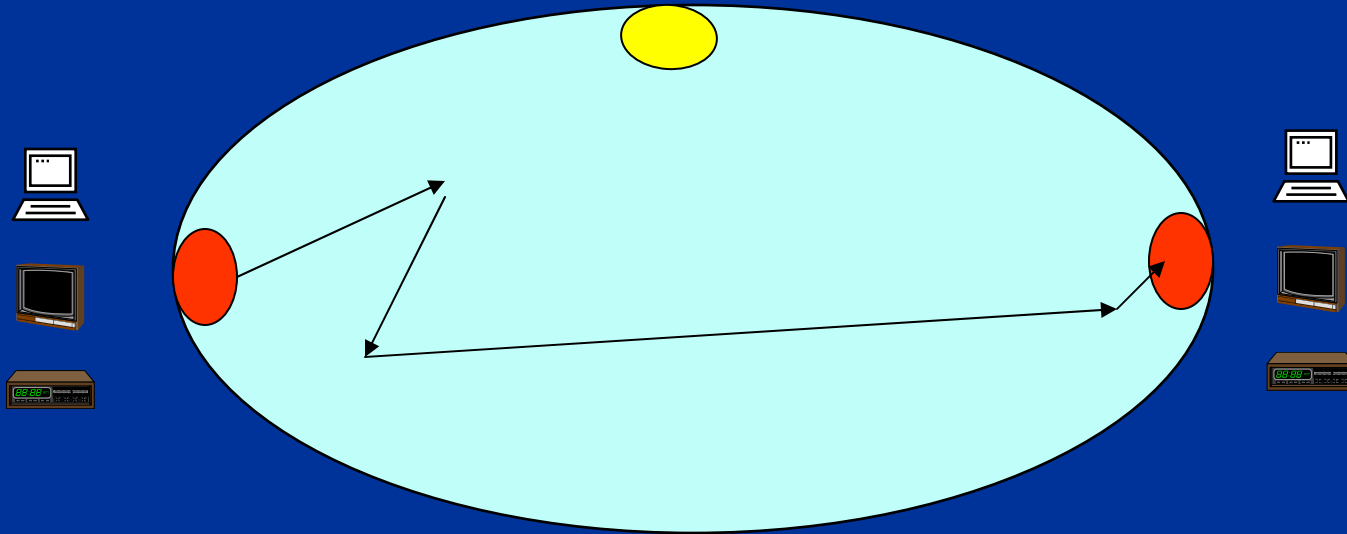

- Each packet header has the destination address, which is used by the routing tables in each router to determine the packet's path.
- Each packet is carried (“best endeavours”) across the network.

**(Very simplified)**

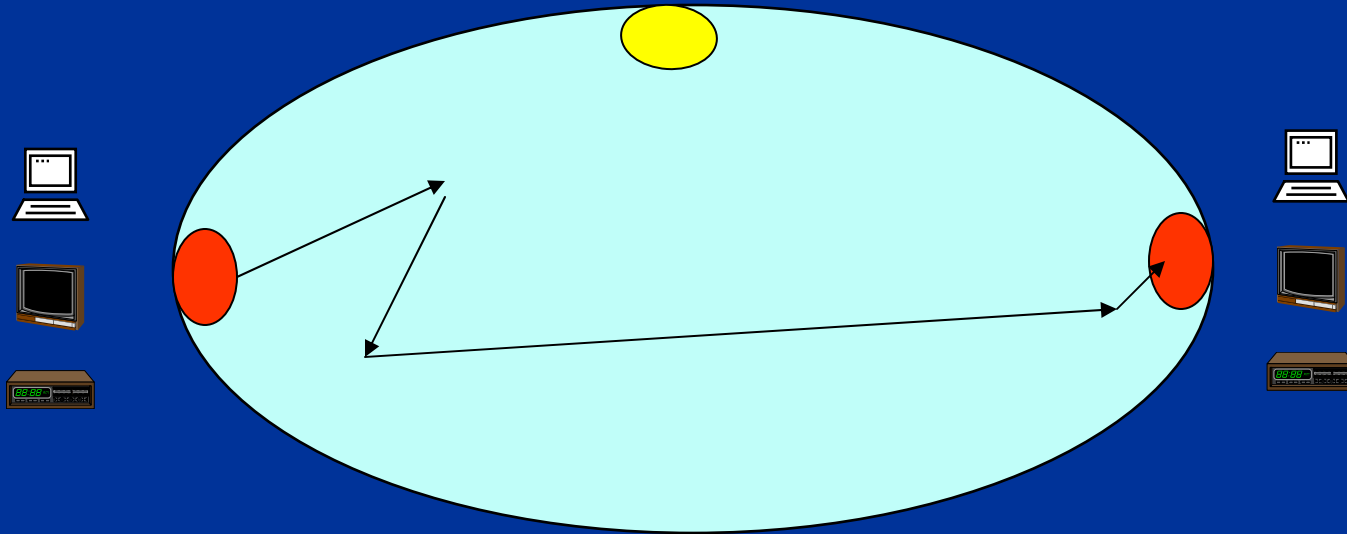

- **Each packet is discarded if it does not reach the destination.**
- **The destination equipment uses the Transmission Control Protocol (TCP) to acknowledge the packet (with a return packet). Lost packets are resent.**

**(Very simplified)**

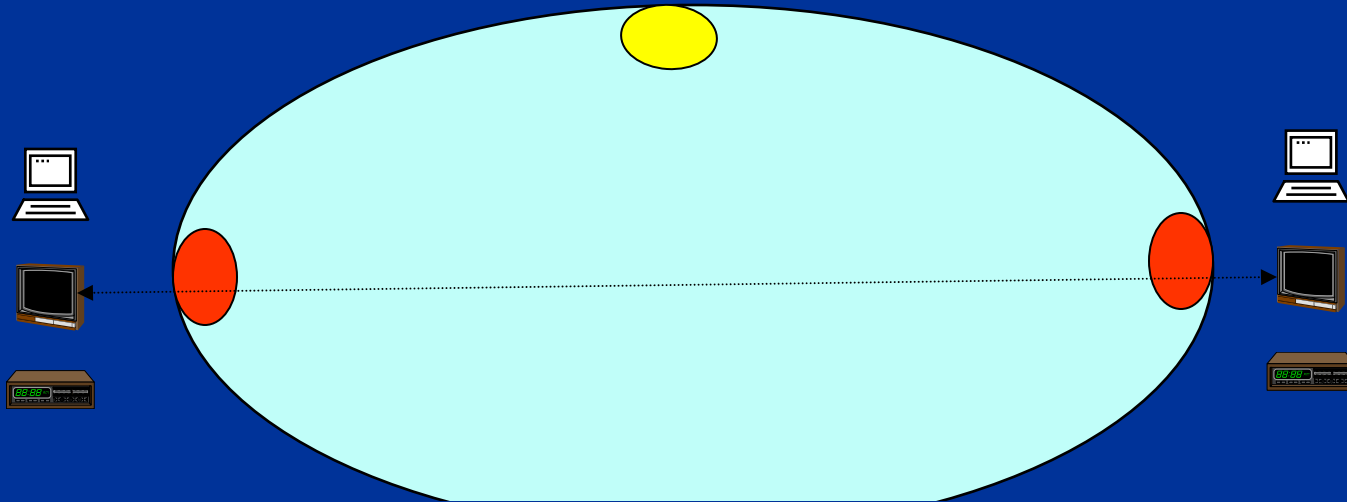

- **At the destination, additional information (e.g peter.darling) is used to route further to the final destination.**
- **The full message is split between packets. Each packet is routed independently, and could take different paths.**

## Internet advantages

- **Open interfaces support rapid innovation (e.g. World Wide Web)**
  - **Able to operate over a wide range of networks/equipment, still using the same end-to-end protocol**
  - **Network able to survive major interruption**
  - **Very efficient use of available resources – packets can be queued to give close to 100% utilisation**

## Internet problems

- **Best endeavours network – no guarantee of delivery**
- **Quality of service cannot be controlled**
- **Latency problems – “one size fits all”**
- **Security, etc**

**The current “Internet” does not meet minimum telco requirements**

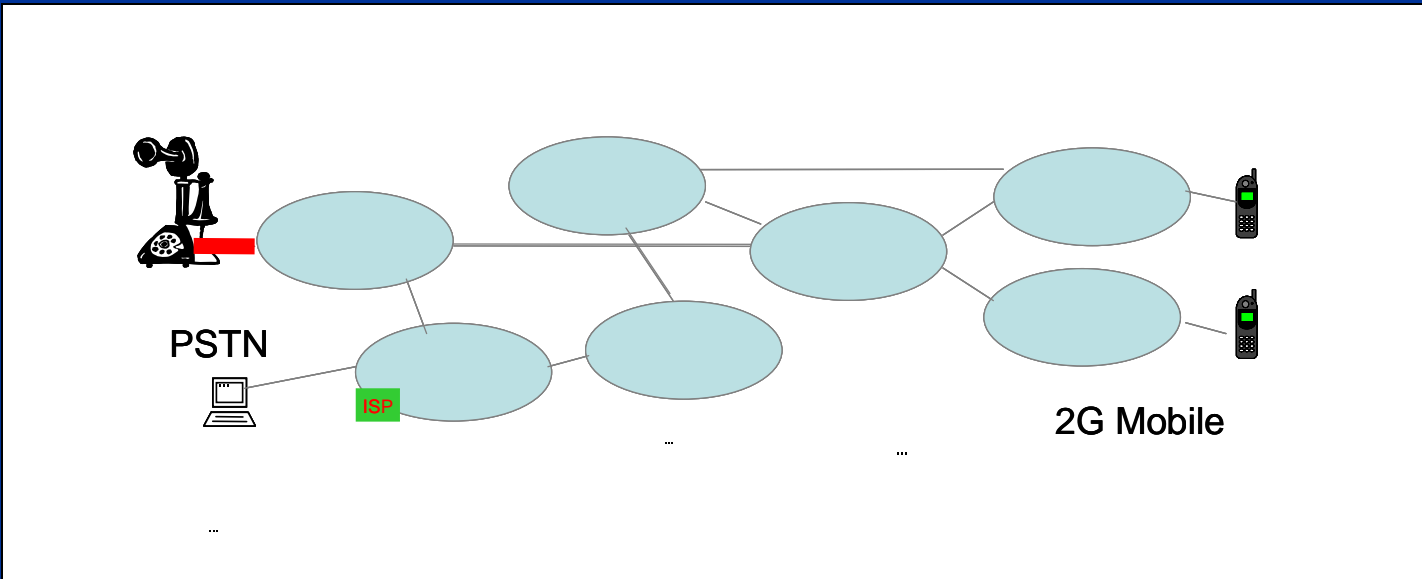

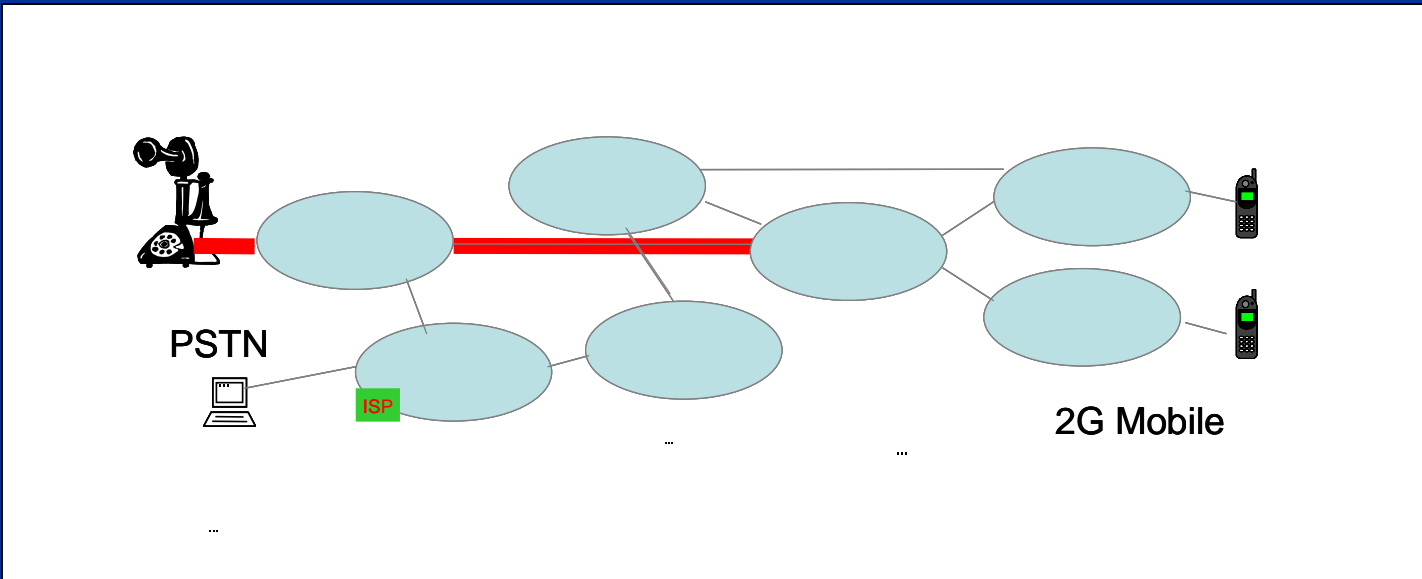

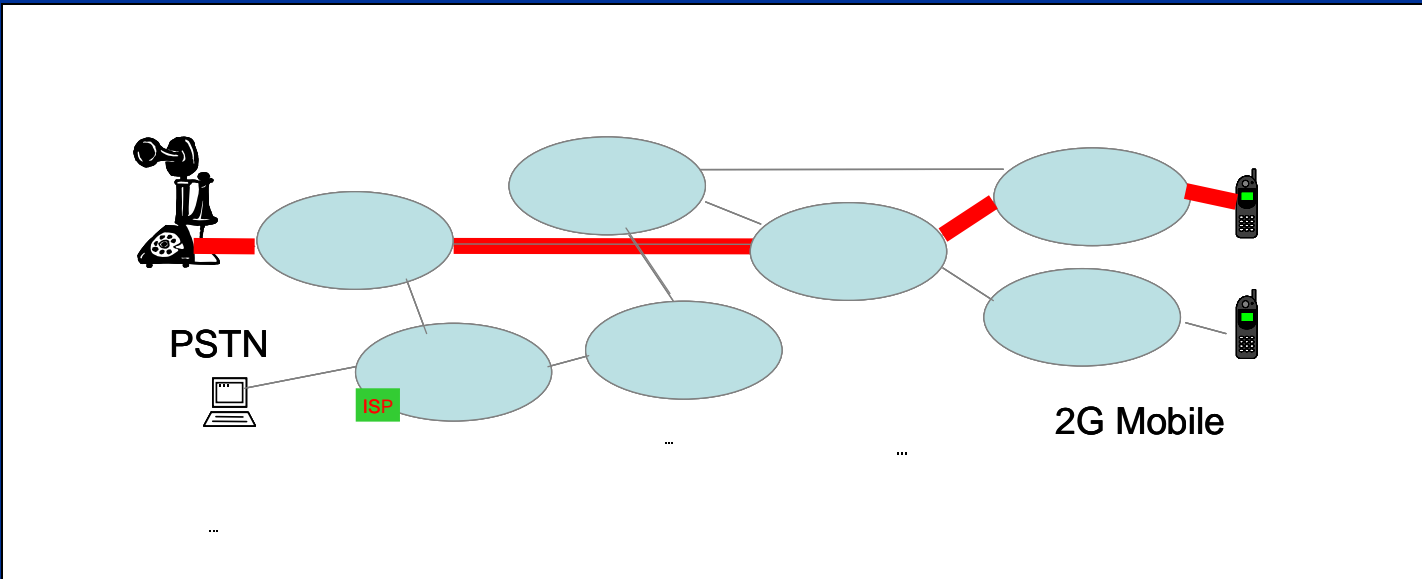

# A Simple Model for most Networks

## The Core Network:

- The heavily used central part of the network
- Traffic from multiple users is combined, allowing economies of scale.



# Access & Core Networks

## The Access Network:

- Provides access to the core network for individual users (and groups of users);
- Must be always available, carrying lower average levels of traffic



# The Analogue Generation

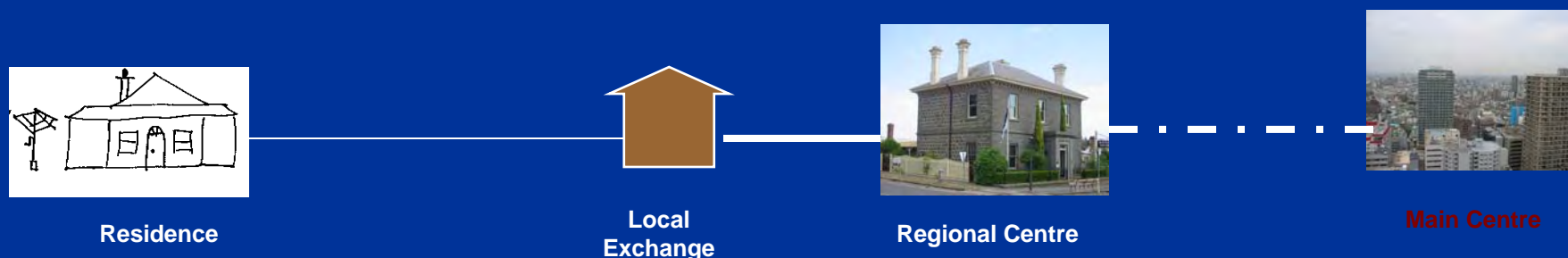

- **Analogue voice end-to-end, via**
  - Copper wires from user to local exchange;
  - Copper wires in local network;
  - Amplified circuits in long distance networks
- **Local relatively cheap**
- **Long distance relatively expensive**

# The Current (Digital) Generation

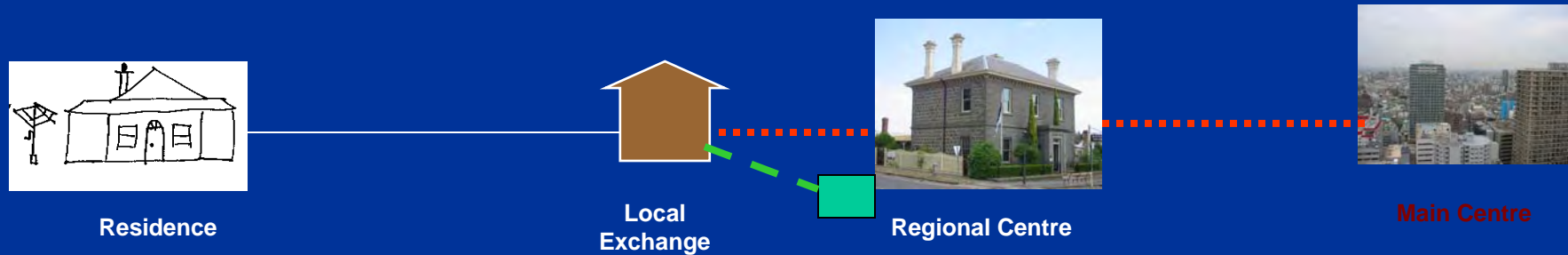

- **Analogue voice over copper to local exchange**
- **Digital connection across network – 64 kbit/s circuit switching**
- **Control centralised at regional centre**
- **Services provided from exchange control (i.e. within network)**

# The Current Internet

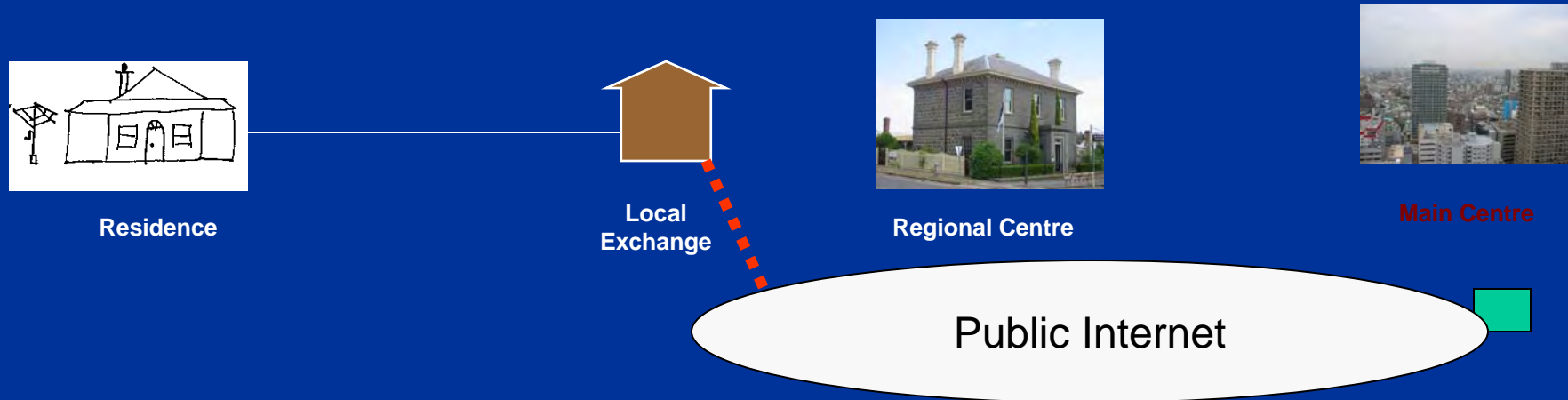

- **Access via ISP reached by dial-up or broadband (with separate commercial relationship)**
- **Services provided at various locations “at the edge of the network”**
- **“Best endeavours” network**

# Next Generation

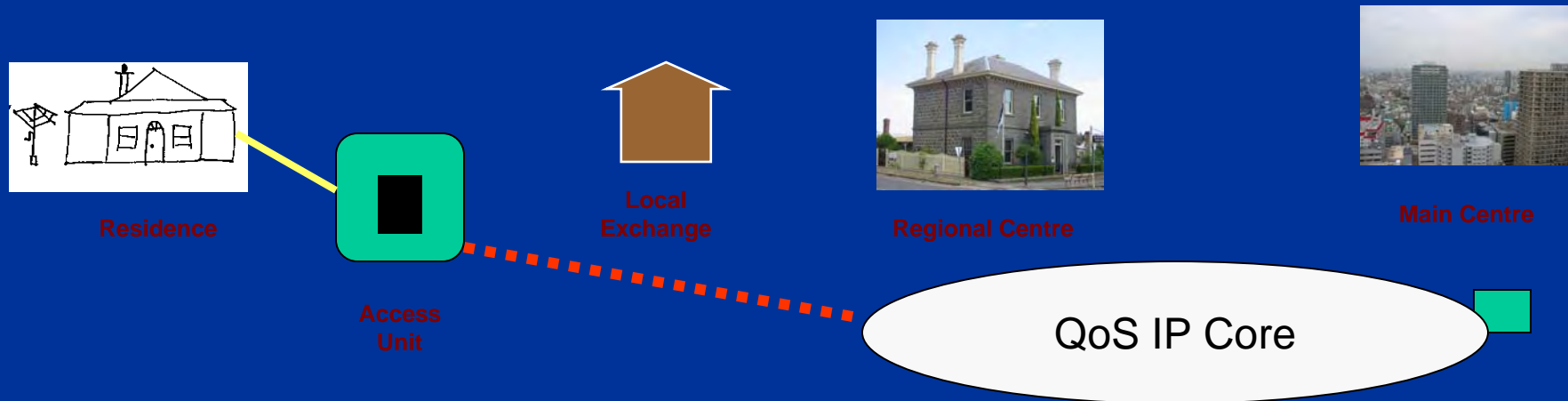

- End to end IP, with full Quality of Service
- Access over different media to QoS IP core (e.g FTTN, FTTP, 3G, WiMax)
- Services provided at edge of network
- Full quality, able to support interactive services such as voice (telephony)

# NGN Layers – ETSI TISPAN

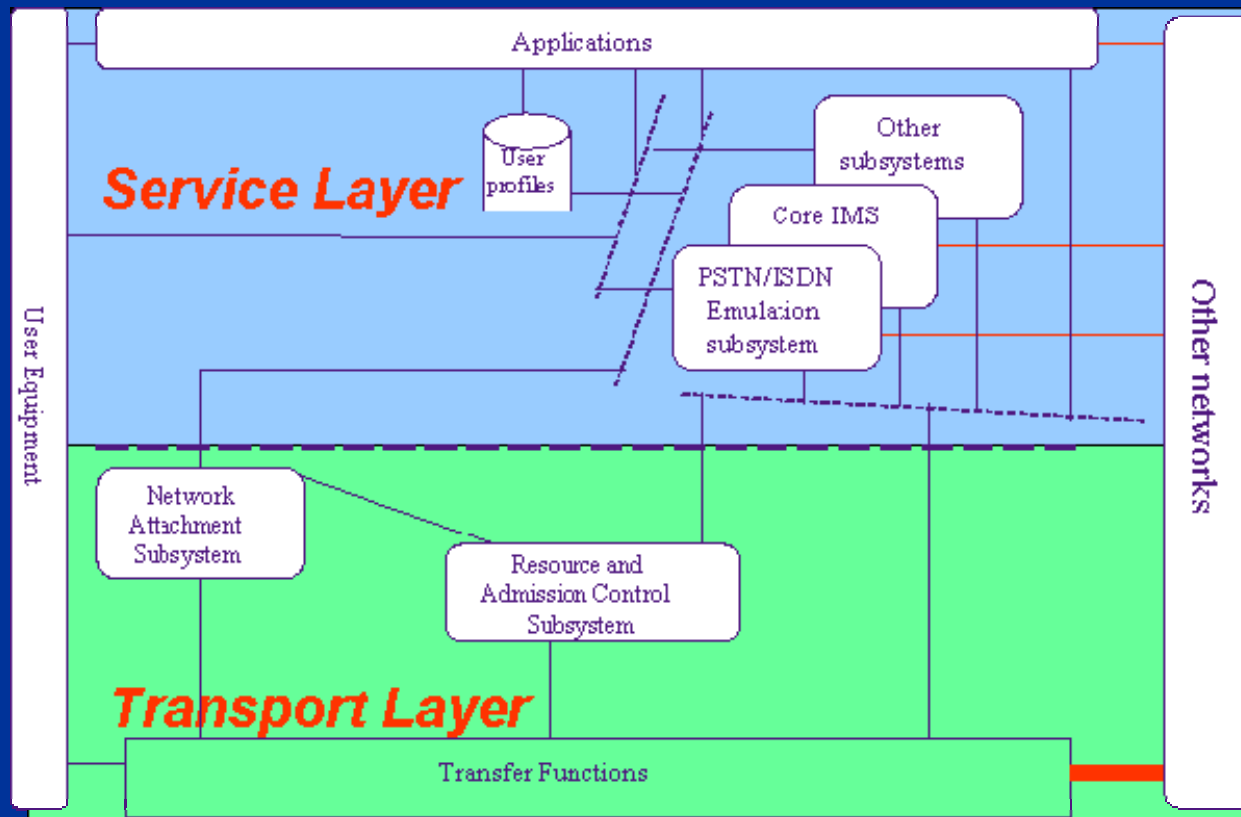

Networks are specified according to a “layered” structure

## Users in the NGN

Users of these networks could be:

- Fixed, always accessing the network from one location;
- Mobile, accessing the network over a wide area, either while in motion or stationary; or
- Nomadic, accessing the network from a fixed location which changes over time (e.g. home, coffee shop and office).

# NGN Technology- Summary

## Key technical characteristics of NGNs :

- a single IP-based core network handling the full range of telecommunications services;
- an access platform supporting the full range of access technologies and services; and
- distributed rather than centralised switching, routing and network intelligence enabling remote access, control and maintenance.

## “Next” or “Now”?

- Many of the networks now being installed seem to come close to the NGN Definition, at least within a single network.

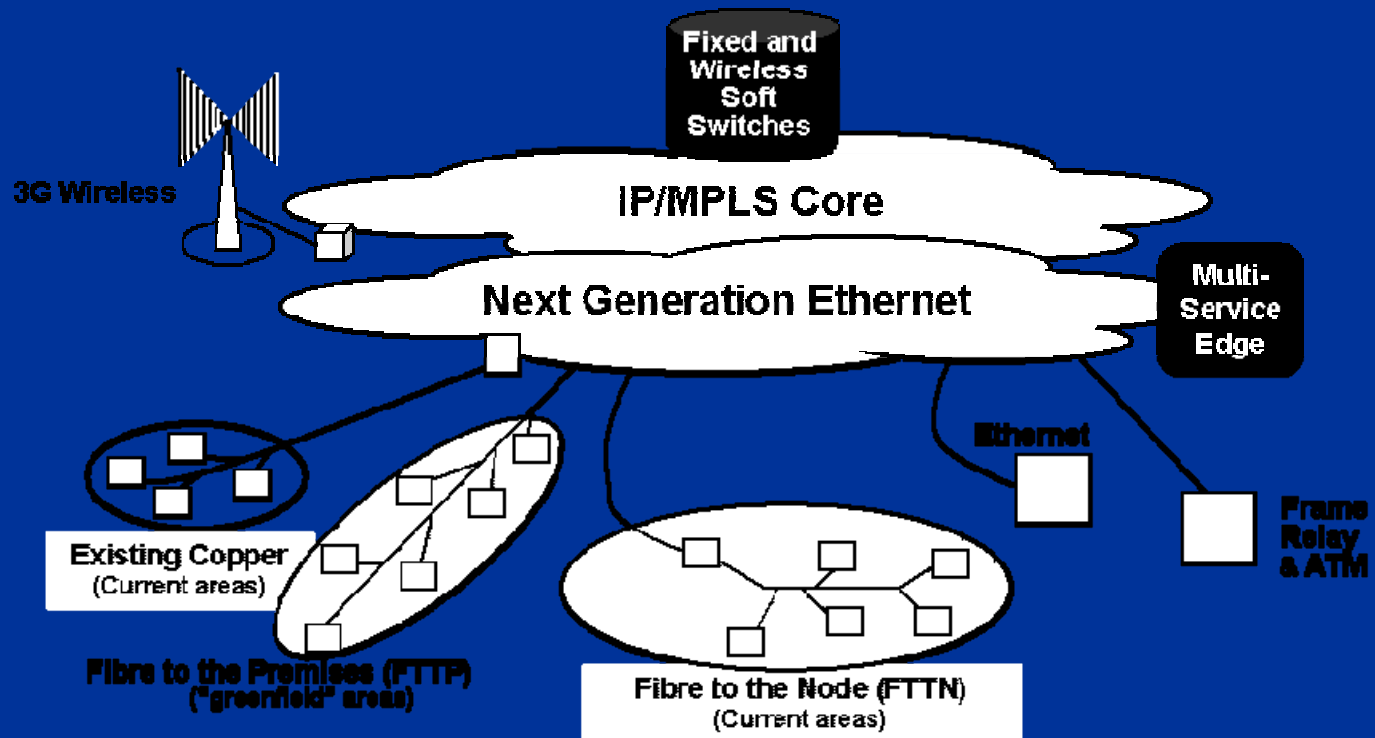

[From Telstra's  
Modernisation  
Plans]

## How will “NGNs” Develop?

- **There are a number of options (not mutually exclusive)**
  - **From the existing public Internet**
  - **From the introduction of enhanced Internet Networks for corporate customers**
  - **From the introduction of new networks using packet technology**
  - **From the upgrading of existing networks using packet technology**

## Evolution to the NGN

- **“NGN” has largely been a concept from the telecommunications providers (“telcos”);**
- **NGNs will not be “the Internet”, but will have many shared features;**
- **As the next slides discuss, NGNs could evolve from either current telephone networks or the current Internet;**
- **Real world NGNs will have aspects of both.**

## NGN Access Service

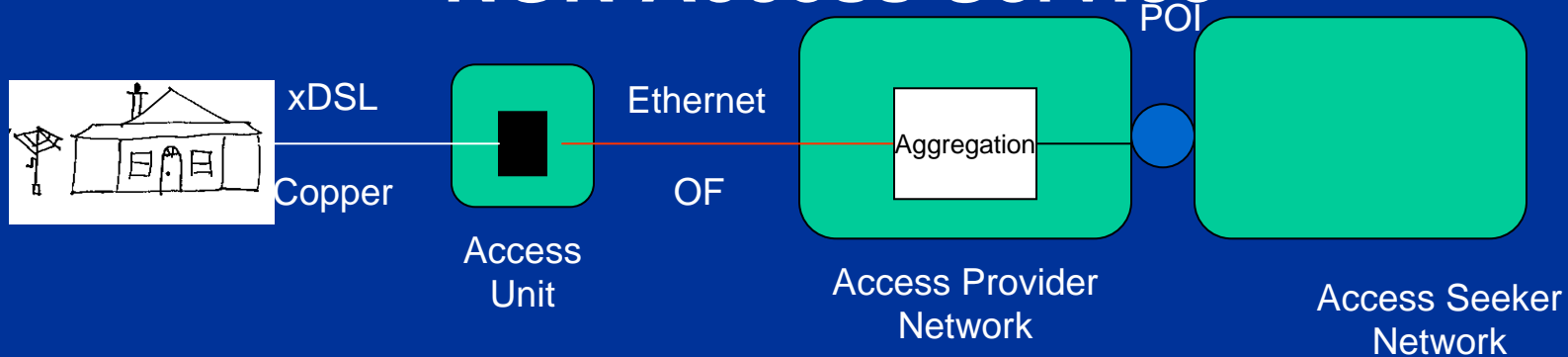

- **The Access Provider could provide a wholesale Transport Access Service to other service providers**
- **This service could support full QoS by either**
  - Layer 2 (e.g Ethernet); or
  - Layer 3 (QoS IP)

## NGN from the (Public) Internet

- The NGN Access Service would primarily access the Public Internet, although separate facilities to support telephony may be provided;
- The Internet Backbone would have to be upgraded to support end-to-end QoS for the full range of end-to-end services; and
- Existing Internet security concerns would have to be resolved.

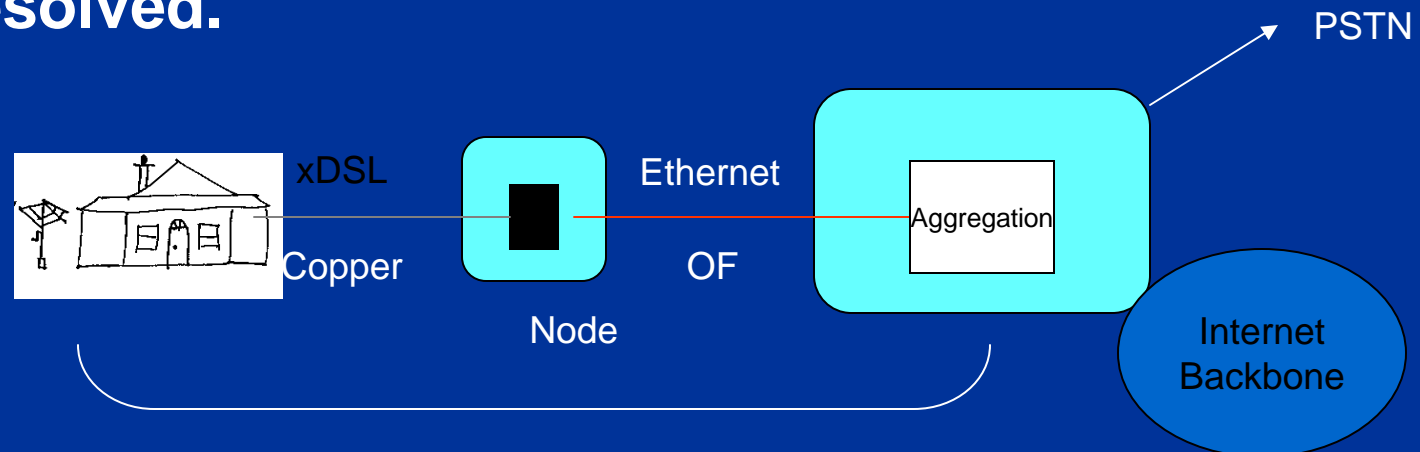

## NGN from the Telephone Network

- “NGNs” will work together in a similar way to the current PSTN.
- End-to-end QoS will require end-to-end control, with new operational standards being developed.
- Access to the Public Internet is also likely.

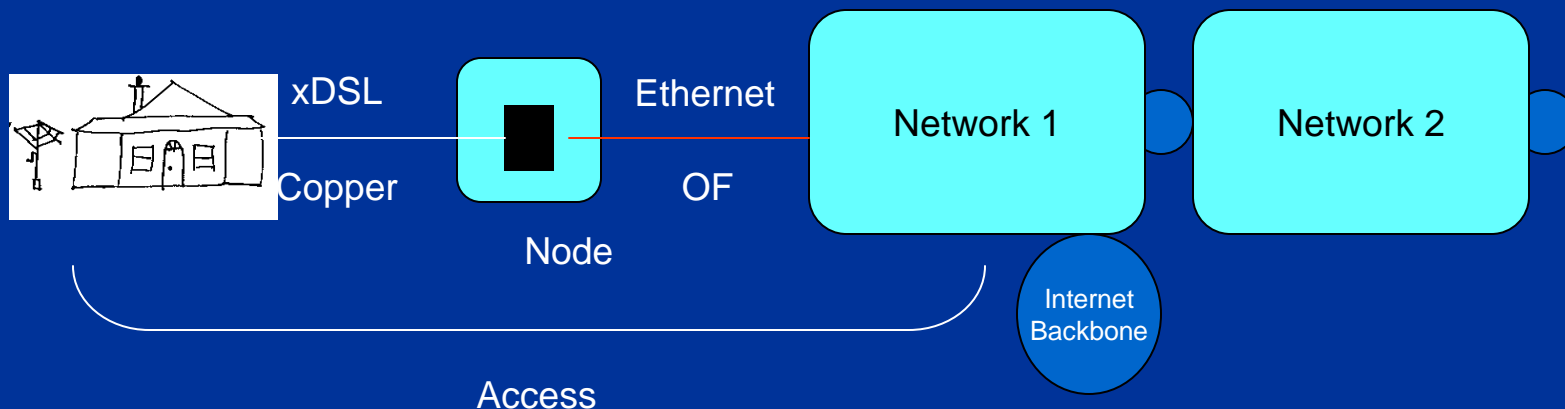

# Innovation on Telco Networks

- **Special arrangements with one operator – normally if what you want does not fit into "business as usual" it will be rejected.**
- **Special arrangements need to be made for interconnection with each other operator on which the service is to be available**
- **The new service has to be added to all the charging and billing both for retail and wholesale (interconnection)**
- **The roll-out of the service is very slow**

# Innovation on the Internet

- **Open Access**
  - Anyone can introduce an innovative service without any special arrangements with operators - you just buy a normal access.
- **Innovation without permission**
  - Anyone on any operator can use the service without any further actions
  - Hence a new service can be offered to the whole world immediately.

## **The Importance of Quality of Service**

- The NGN should be able to support real-time interactive services, including voice and also multi-media services such as two-way video communication**
- The NGN will need to provide a continuous Quality of Service (QoS) level greater than the QoS currently provided from the Internet at times of congestion**
- Despite IETF work, there still seems to be no clear way of guaranteeing end-to-end Quality of Service across networks with current Internet implementations.**

## How to Provide Required QoS?

- Provision of the required QoS level can be done in a number of ways:-
  - based on proprietary approaches developed by network equipment vendors
  - Based on agreed industry standards (primarily protocols developed in the IETF),
  - By ensuring that there is no link or router congestion at any point in the end-to-end packet paths in use during a call (or session), either for all links or by choice of selected routes.

# Interconnection and Interoperation

## The current situation:

- Implementation of almost all work in the IETF on techniques to provide assured QoS has been directed to a single network rather than across networks/autonomous systems
- many different approaches based on IETF protocols and proprietary developments are now in service in different networks.

# Interconnection and Interoperation

**End-to-end connectivity is not assured, and priority work is needed if the NGN is to be more than single network hype.**

- Standards**
- Commercial implementation**

# An Interconnection Approach

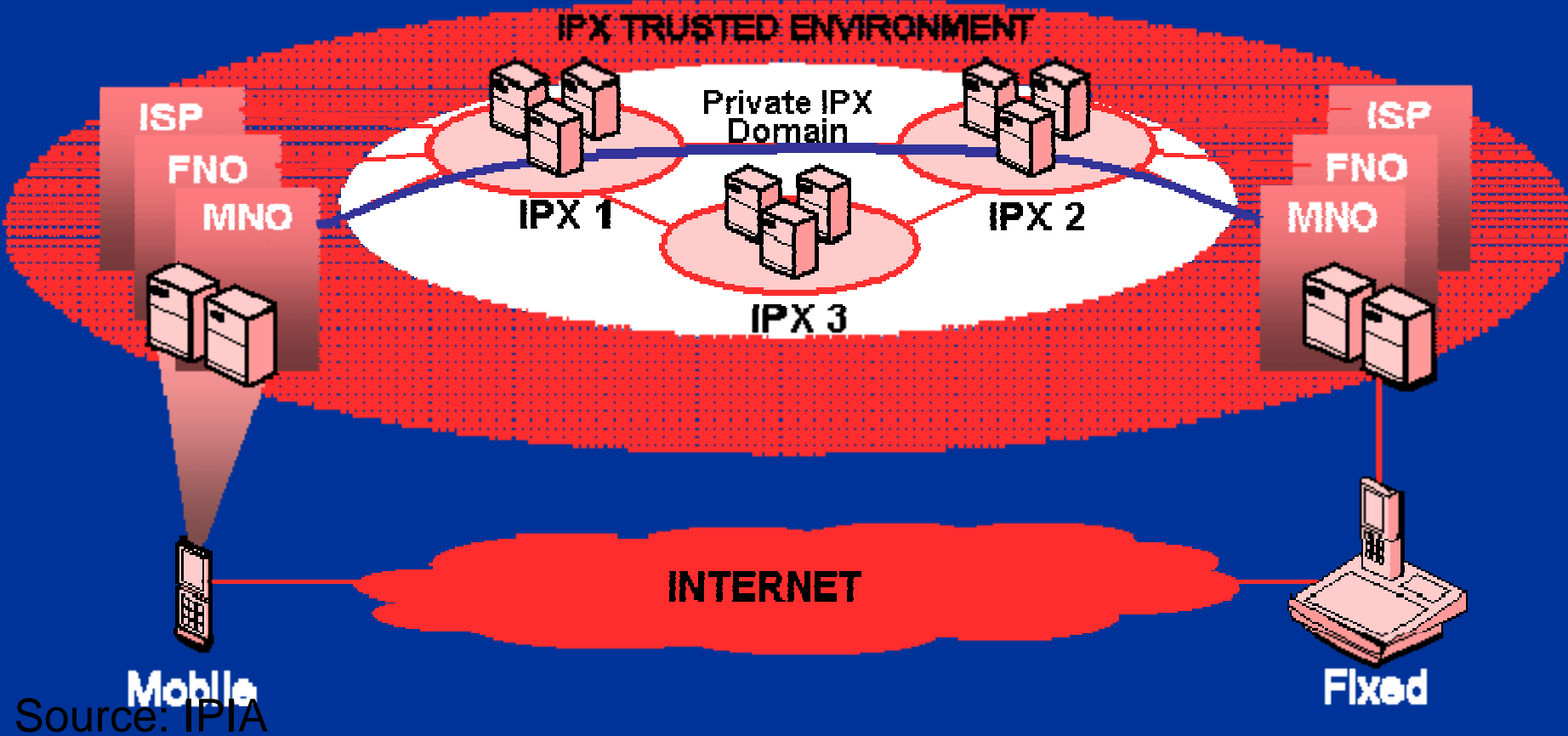

# NGNs

- **Access technology is crucial for future network development;**
- **It is unlikely that it will be economic to duplicate NGN access technology to fixed users in many areas;**
- **Provision of a clearly defined, open wholesale NGN access service will be essential to support competition in networks, services and applications.**

# NGNs

- **One of the major policy challenges in the transition to the NGN environment will be to strike an appropriate balance between ensuring the continued availability of socially important services (particularly telephony) from the current environment and supporting innovative new services and applications for the future.**

**NGN**



**Broadband**



**Pondarosa Communications Pty Ltd**  
**PO Box 1072, Kyneton, Vic 3444**  
**[Pondarosa.Communications@gmail.com](mailto:Pondarosa.Communications@gmail.com)**